

CleanSweep®

CleanSweep Инструкция по эксплуатации

Precision Planting®

Содержание

Начало работы.....	4
Обзор системы.....	5
Установка пульта CleanSweep.....	7
Подключение компрессора к пневмосистеме.....	8
Установка и подключение компрессора CleanSweep	10
Подключение питания к компрессору CleanSweep.....	12
Обзор компрессора CleanSweep.....	13
Крепёж компрессора.....	14
Тестирование системы компрессора CleanSweep.....	18
Работа с системой компрессора CleanSweep.....	20
Устранение неисправностей.....	21
Комплект крепежа очистителя рядка и установка пневмоцилиндра.....	23
755160 — Yetter Titan 2967–042, 043.....	25
755170 — Yetter Titan 2967–115.....	32
755175 — Yetter Titan 2967–035 (Short Bracket)	38
755180 — Yetter Titan 2967–035	45
755185 — Yetter Titan 2967–007	54
755190 — Martin C-125: MTS, MTS-XP, or MTS-IH	61
755195 — Martin C-125: MTR, MTR-XP, or MTR-IH.....	68

755200 — Martin BD1360.....	76
755205 — Martin BDC 1360.....	85
755210 — Yetter Titan 2967–029.....	92
755225 — Martin MTR (Low Mount Option).....	99
755230 — Yetter Titan 2967–035.....	108
755245 — Yetter Titan 2967–097.....	118
755250 — Yetter Titan 2967–013/14 (Case Row Unit).....	125
755255 — Yetter Titan 2967–013A/14A/029A/097A	132
755265 — Yetter Titan 2967–029/097	135
755270 — Yetter Titan 2967–013/014	140
Соединение/Прокладка пневмолиний.....	145
Прокладка пневмолиний — Обзор.....	146
Прокладка пневмолиний — Высевающая секция.....	149
Комплекты фитингов пневмолиний.....	151

Начало работы

Шаг 1:

CAB INSTALLATION

Begin installing your CleanSweep by mounting the Controller within the cab of the tractor. Position the Controller within reach during operation without compromising safety or visibility from the cab. Route the hoses from the rear of the Controller to the hitch-point at the rear of the tractor. The provided unions at the far end create a quick disconnect point for the CleanSweep system.

Шаг 2:

CONNECTING TO THE AIR SUPPLY SOURCE

Ensure the supplied air is clean and dry. “Contaminated Air” will lead to premature cylinder failure.

When sourcing from the AirForce Compressor: Use the supplied installation components to tap into the tank circuit of the AirForce system. This connection will be made AFTER the water separator and BEFORE the AirForce control manifold.

When sourcing from the CleanSweep Compressor: Connect the supply tube from the controller to the output side of the water separator within the compressor module.

When sourcing from the OEM compressor: This installation is **NOT SUPPORTED** by Precision Planting. Cylinder life can be greatly reduced by contaminated air. Use of compressors other than the CleanSweep or AirForce compressor will void the warranty on the cylinders.

Шаг 3:

INSTALLING THE CLEANSWEEP COMPRESSOR

Begin by connecting and routing the Tractor Battery Power Cable on the tractor to source 12V power from either the battery or starter. Next locate a suitable mounting location for the compressor assembly. Placement of the compressor assembly will vary on the make and model of the planter.

Note: Be sure to check clearance of compressor assembly in all locations, especially noting tractor tires and folding/unfolding the planter for transport mode.

Шаг 4:

INSTALL BRACKET KITS AND CYLINDERS

Шаг 5:

CONNECTING AND ROUTING AIR LINES

Install the air lines, down and lift pressure circuits, to the cylinders. Route the air lines safely from the cylinder and connect to the trunk line on the planter frame. Route the main trunk line forward to the rear of the tractor to connect with the hoses from the controller. ENSURE THE PLANTER IS CLEAN BEFORE BEGINNING INSTALLATION OF THE CYLINDERS OR LINES. ANY DIRT OR DUST INSIDE OF THE LINES OR CYLINDERS WILL REDUCE CYLINDER LIFE. Install the Row Cleaner Bracket Kits and Cylinders. Refer to specific instructions in this manual.

Обзор системы

The CleanSweep row cleaner control system consists of four primary components and kits. These parts include; the CleanSweep Controller, the air supply source, row cleaner cylinder kits, and the necessary lines and fittings.

Пульт CleanSweep

The CleanSweep controller will be cab mounted, giving control of the forces on the row cleaners. The controller has three analog gauges to display the pressures in each circuit. Only two gauges, at most, will ever have pressure at the same time. Moving the control lever to the left increases lift force, effectively removing weight from the row cleaners. Moving the control lever to the right increases the down force, effectively adding weight to the row cleaners.



Источник сжатого воздуха

CleanSweep requires a stable air supply source that can provide 120+ PSI of clean, dry air. This is a key component of the air supply; moisture within the air supply can shorten the life-cycle of the cylinders. The two approved sources are: an existing 20/20 AirForce compressor, or the CleanSweep Compressor. Both systems are capable of supplying the required air pressure and volume. AirForce compressors are capable of supplying the pneumatic pressure required for a CleanSweep system in addition to any pneumatic clutch and downforce already present.

AirForce®

OR



Пневмоцилиндр и комплекты крепежа

Each row to be controlled will have an air cylinder and bracket kit to be installed on the row cleaner. Each kit will include the required brackets and hardware to pair with the cylinder to modify an individual row. These will be specific to the make and model of row cleaner to be controlled.



Комплект трубочек и фитингов

line and fitting kit will be used to move air from the tank to the controller, and then out to each air cylinder. Each kit will include pneumatic lines for both circuits, down and lift, as well as the fittings to make connections and cable ties to securely fasten the lines to the planter



Note: All AirForce and CleanSweep compressors include a tubing cutter within the service kit. This cutter should be used for every cut, to ensure a clean, square cut.



Установка пульта CleanSweep

Once an adequate mounting location has been located, fix the base component of the Mounting Bracket (725258) in place. Fix the head component to the rear of the Controller and reconnect the two components of the Mounting Bracket.



Serial number and Registration Code can be found here.



RAM mounting brackets may be used as an alternative means of mounting the Controller, but is not the preferred method.

Note: If the control lever becomes loose or begins to “creep” while under pressure, using a 9/16” wrench, tighten the lock nut on the rear of the regulator.

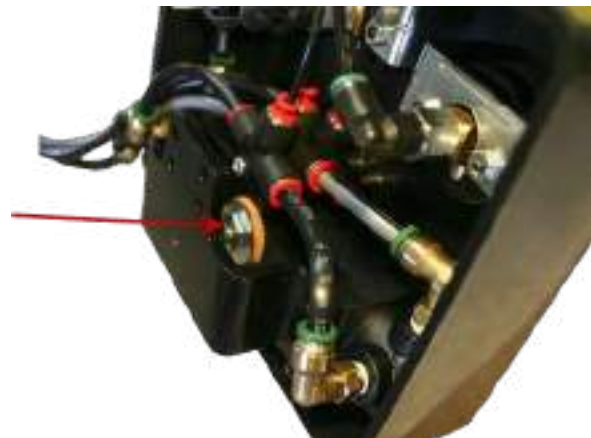

Подключение компрессора

The air supply for CleanSweep may be sourced from an existing AirForce compressor (if present) or from the CleanSweep specific compressor. The CleanSweep system should have a ready supply of air at 120 PSI or greater that is clean and dry.

Note: Drain the air tank of all pressure prior to proceeding to the following step.

12V Compressors

Using the tubing cutter supplied in the Service Kit Assembly, measure down 1-1/2" to 3" down from the inlet check valve assembly and cut the line leading to the accessory air chuck.

Re-connect the accessory line with the addition of the provided 1/4" PTC Tee.

If it becomes necessary to remove the accessory line from the inlet check valve, make a mark flush with the assembly body (or 7/16" from the end). Re-install the accessory line no further than this mark to prevent air flow disruption.

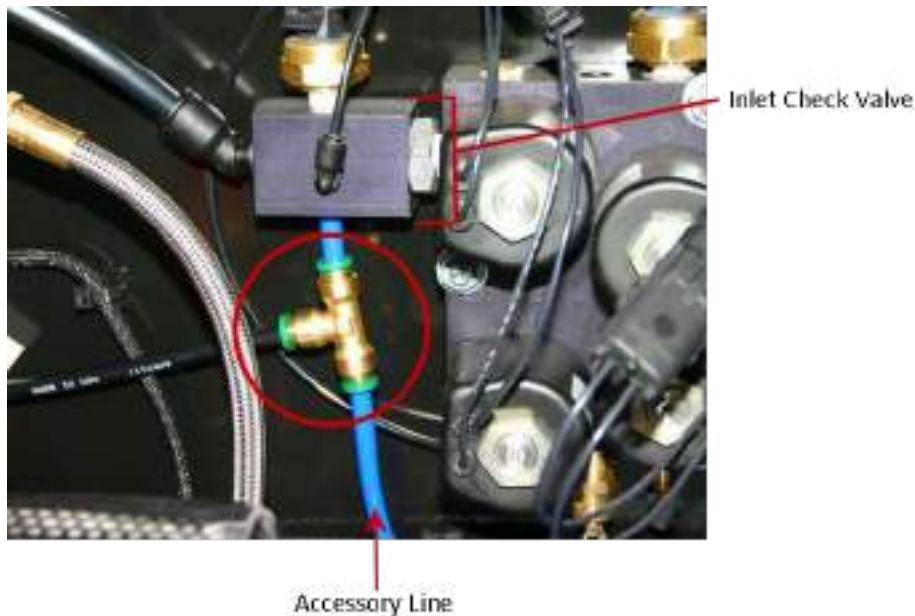

Complete the process by installing the 1" rubber grommet (726472) into the cutout in the base of the enclosure in the left rear corner behind the compressor. Route the 1/4" Supply Line through the cutout now protected, along the rear of the enclosure and connect into the Tee. Route the opposite end of the Supply Tube forward and connect using the union at the hitch of the tractor to the supply line from the controller. Use the brown tubing from the compressor to the control box so that it is easy for the operator to identify the tubing that should be connected in the cab.

Hydraulic Compressors

Using the tubing cutter supplied in the Service Kit Assembly, measure down approximately 6" from the outlet of the water separator and cut the line leading to the inlet check valve. Install, in line, the provided 3/8" X 3/8" X 1/4" PTC Tee as shown. Install the 1.75" rubber grommet (726459) as shown in the cutout in the base of the enclosure.

Route the Supply Tube from the Tee through the grommet protected cutout and connect forward to the controller.



It is intended that the supplied brown colored tubings is used from the compressor to the control box to help color code the line as the air supply for ease of attachment to the system by the user.

Установка и подключение компрессора CleanSweep

Mounting of the CleanSweep Compressor

Note: Every planter/tractor combination will contain it's own unique situations in regard to mounting the Compressor Module for clearance and accessibility. **You should exercise your own best judgment to fit your situation.** CleanSweep Compressors require mounting with access to 12V power from the tractor. 26' of the combined cabling is included in the base kit.

Шаг 1:

Locate a possible mounting location. The image below shows the three most common mounting locations and the terms by which we refer to them. Use the diagram on the following page for dimensions and clearance requirements.

Шаг 2:

visually inspect the proposed mounting location for structural stability and to find signs of wear in that location. Possible obstructions to be aware of include marker arms, liquid fertilizer tanks, rear tires (duals especially) during tight turns, etc...

Шаг 3:

Mark out the position of the Compressor then complete a thorough cycle of folding/unfolding to transport mode and raising/lowering of the planter; as well as, driving in a tight circle in one or both directions, in planting position, to verify or identify obstructions.

Step 4:

Once the Compressor is mounted, repeat the previous process very cautiously to once again verify that the Compressor is clear of obstructions.

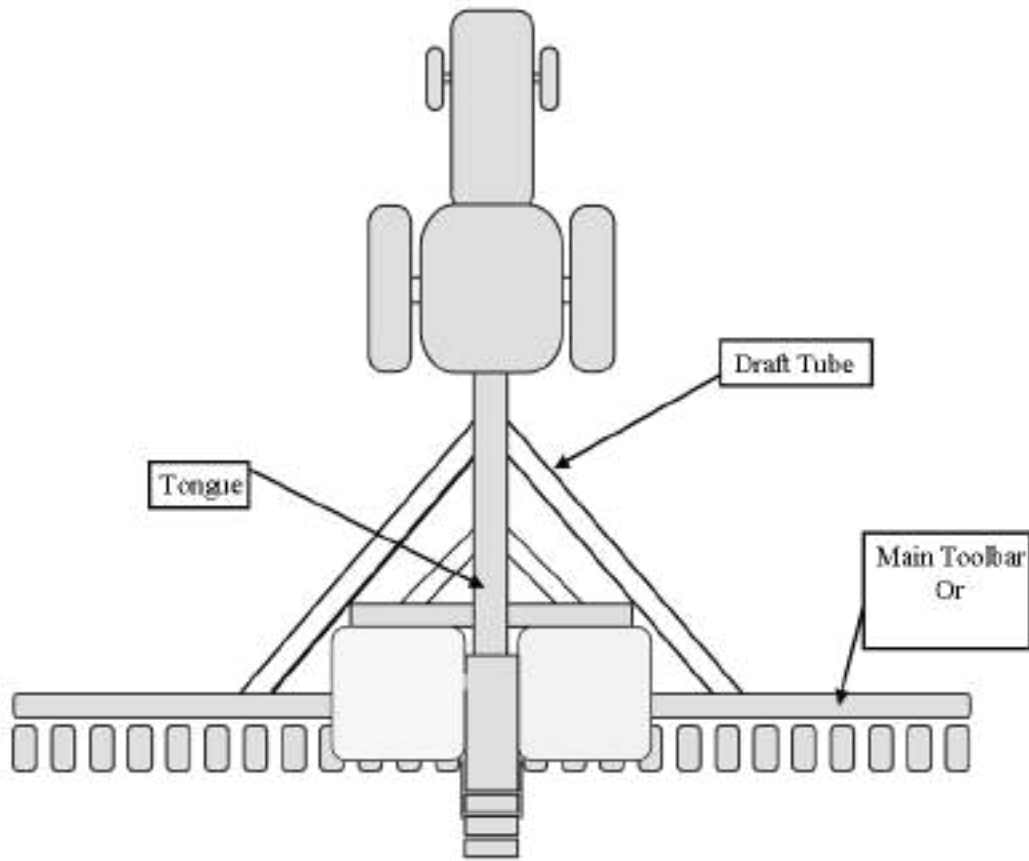

The diagram to the right will help identify possible mounting locations on your specific planter. Allow room for the lid to open properly. Measure 10" vertically and 8" to the rear of the point marked with an *. The 'X' dimension is the spacing between the tank rail bolt holes, on center. The bolt holes are spaced 1" on center, with 1" slots at each end.

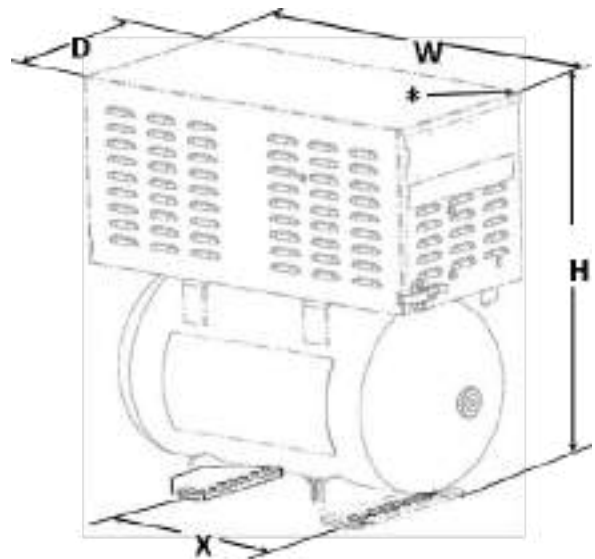

H	W	D	X
16	19	10.5	12

Подключение питания к компрессору CleanSweep

A stable supply of 12V DC power is required for the operation of the CleanSweep Compressor. This system should be installed only on tractors capable of supplying the 18 Amps required to operate the Compressor

The 755015 Tractor Power Harness will need to be connected to both: Constant power and ground (Sourced from the battery or starter post) and Switched power within the cab (Commonly connected at the convenience outlet).



If all convenience ports are currently used, the necessary adapters are available through Precision Planting:

- 725270 JD power strip adapter
- 725254 Power Splitter

Note: The cigarette outlet is **NOT** a switched port on all models of tractors and therefore should not be used.

Обзор компрессора CleanSweep

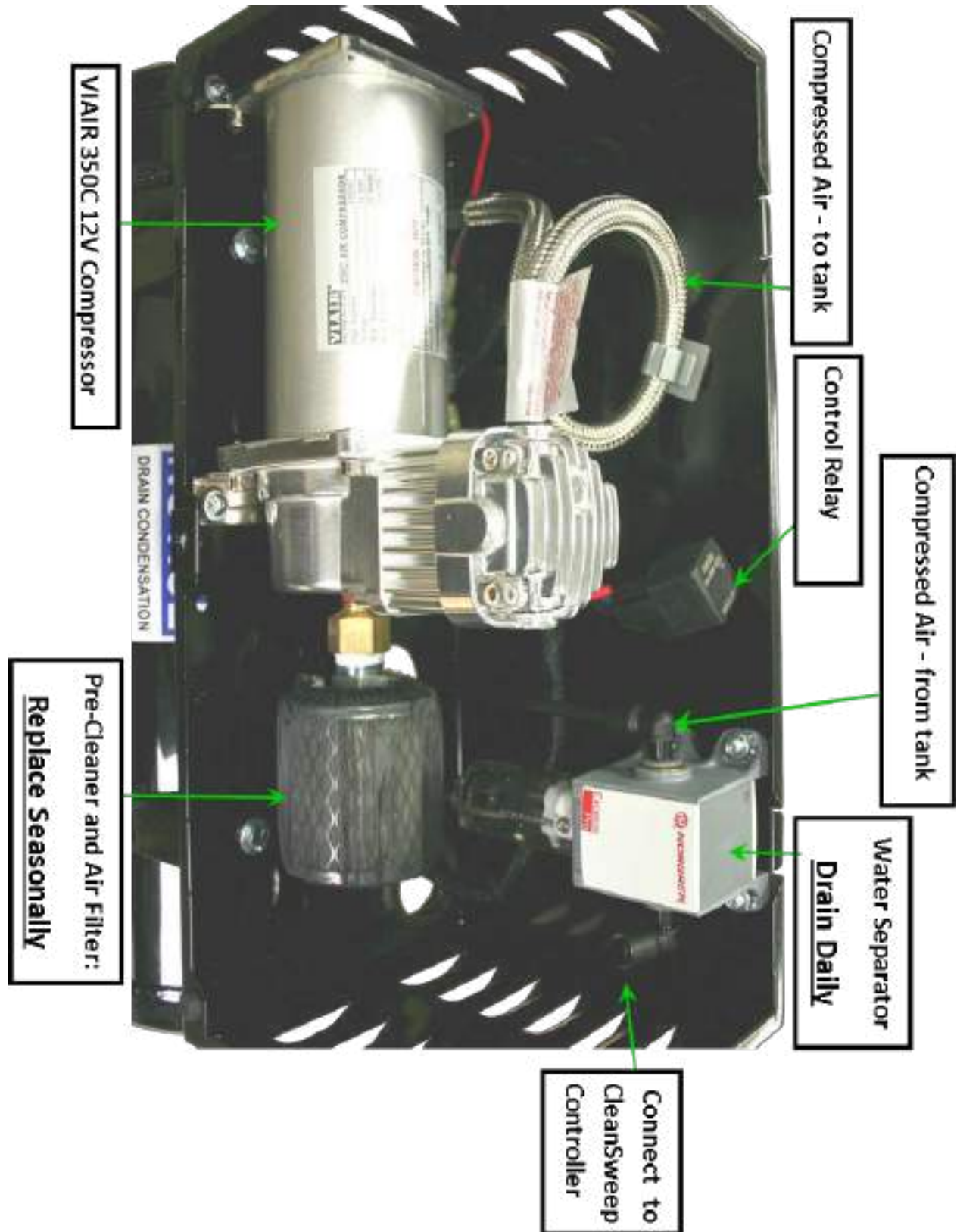

Крепёж компрессора

Part Number	Image	Description	Width in inches (X)	Height in inches (Y)
726050	A	U-Bolt	3	5
726051			3	6
726052			3	8
726053			4	6
726054			4	7
726055			5	7
726057			8	10
726397			4	4
726490			8	12
726059			N/A	Bolts Only
726450	B	Universal (up to 9X10 Bars): Threaded Stud with Brackets		
726056	C	U-Bolt w/ Spacer Bracket	7	7
726058			8	8
726455			10	10
726500			7	4
726435	D	Angle Bracket	Kinze 3700	
726060	E		Kinze 3800	
726470	F	High Above Tube	N/A	
726515	G	Stand — Above Crossbar	N/A	
726612	H	Low, Side Mount	7	7
726613			8	8
726614			10	10
726398	I	J-Bolt	See Image	

See Image

This will be the most common and simple means of mounting the compressor to your planter. Two U-bolts and hardware will be supplied. These will be wrapped around the chosen draft bar, toolbar or tongue location and fix the compressor in place through the base feet on the tank.

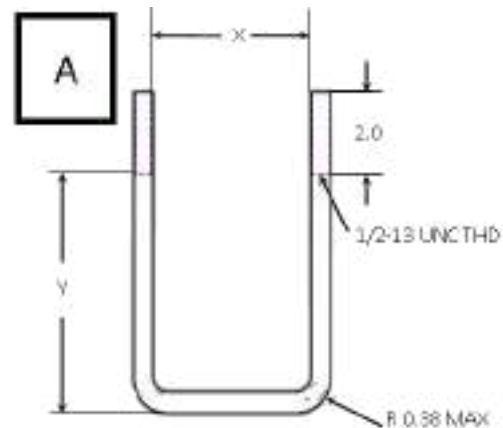

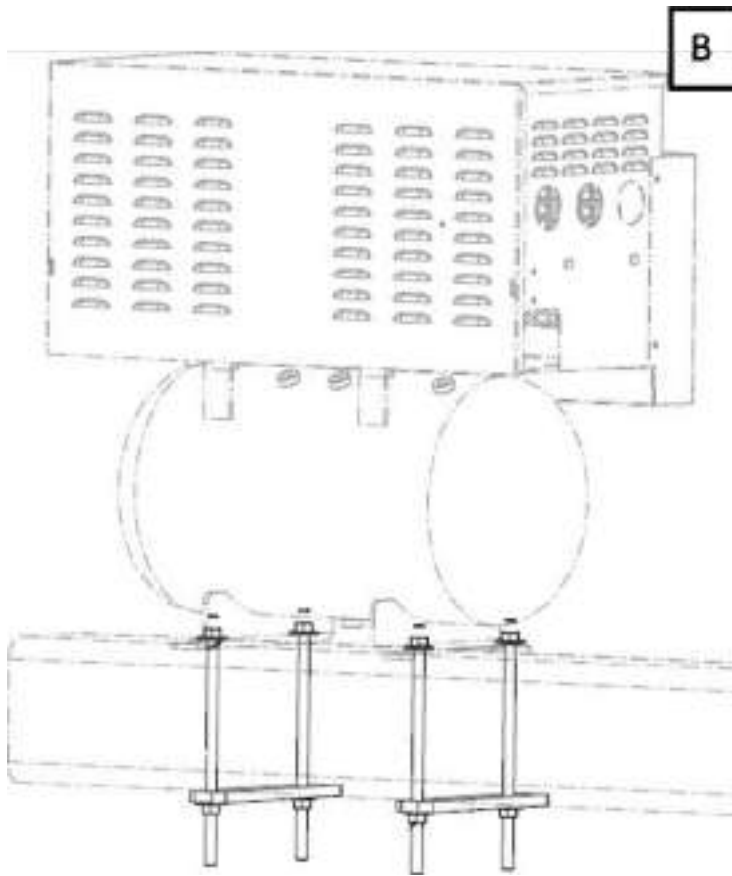

This group of mounting brackets will be most common on Kinze and stack-fold planters and may require the removal of the jack stand mounting bracket. Three U-bolts, three brackets, and the necessary hardware will be provided. Two of the brackets, similar to those shown below, will be used to space the tank above hoses and communication lines on the tongue or toolbar. The remaining U-bolt and bracket will be used to relocate the jack stand on Kinze planters to the vertical riser.

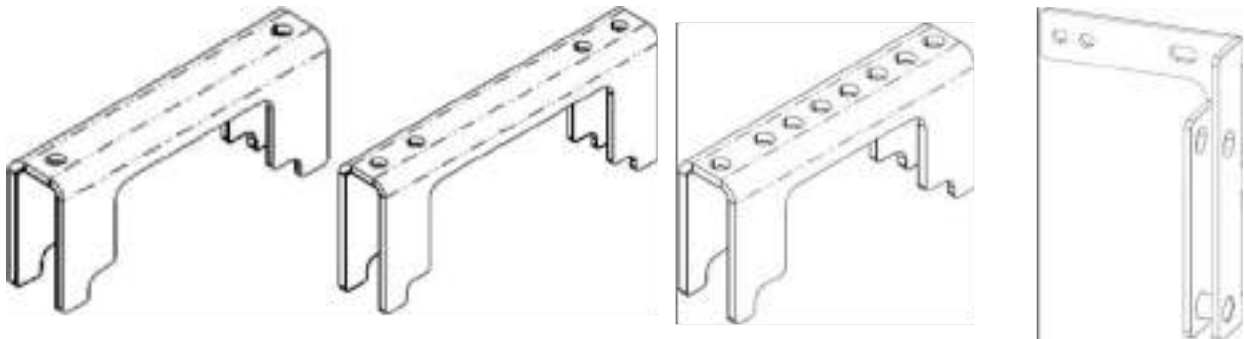
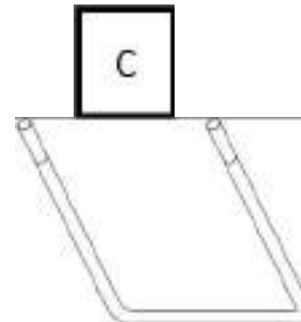

This mounting kit will offer a side mounted position for the Compressor Module. Shown at left mounted on the forward portion of the tongue on a Kinze 3700. Two brackets and hardware will be supplied and some drilling may be necessary.

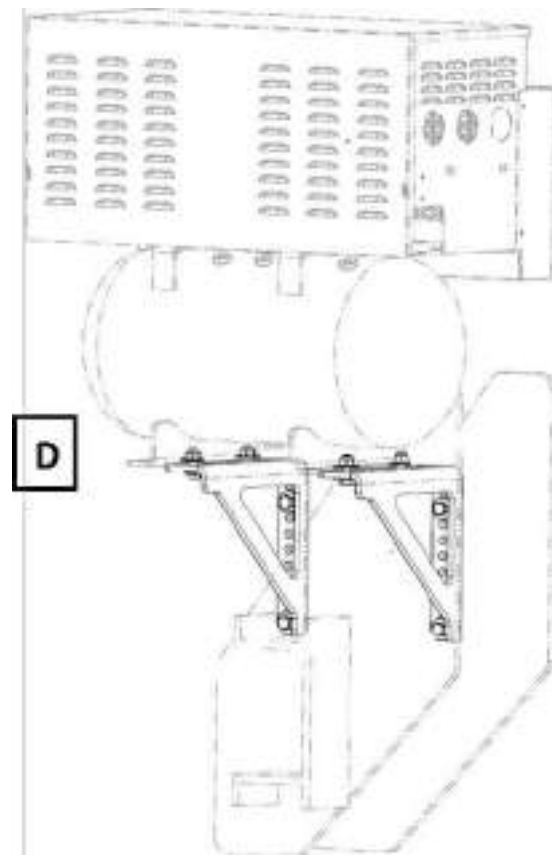

This mounting kit will be very similar to the previous mounting kit. The same brackets will be provided, however there will also be two U-bolts, removing the need for a drilling operation.

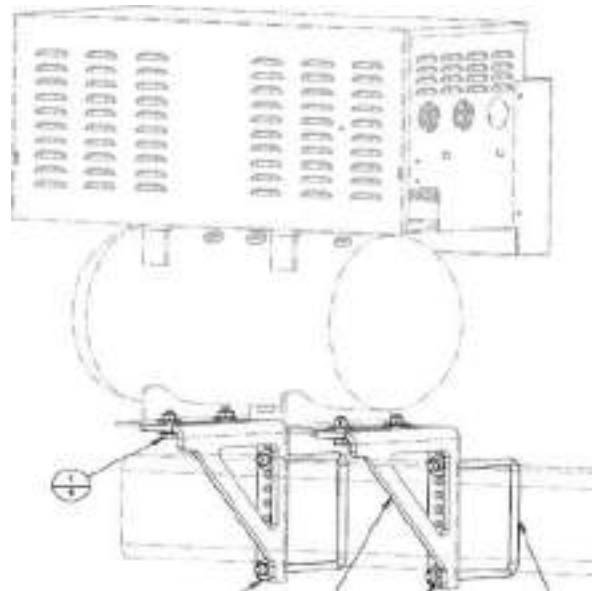

The most common mounting location for larger planters will be on the draft bar. Use this mounting kit for situations that do not provide enough clearance for the compressor to rest directly on the draft bar. Four of the straps shown at left as well as hardware will be provided. This will allow the compressor to be elevated and set back (or forward) to avoid clearance issue.

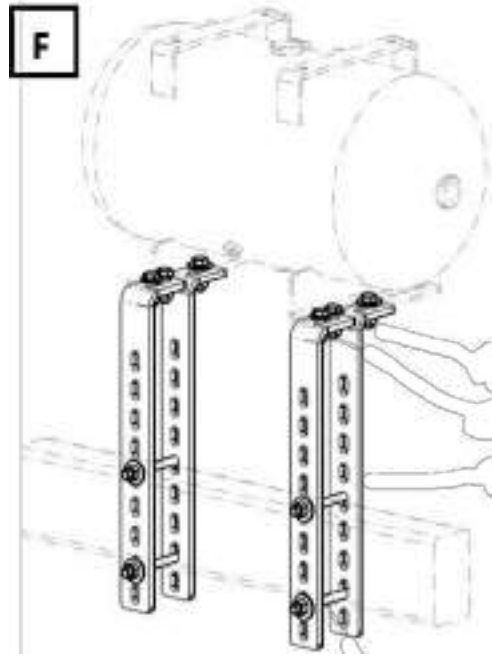

This mounting kit is designed for situations that do not allow mounting on the planter, or require greater elevation of the compressor for clearance reasons. Two of the brackets (shown below right), two straps, two U-Bolts, and hardware will be supplied. The image at left shows the compressor mounted above the 2 point cross-hitch

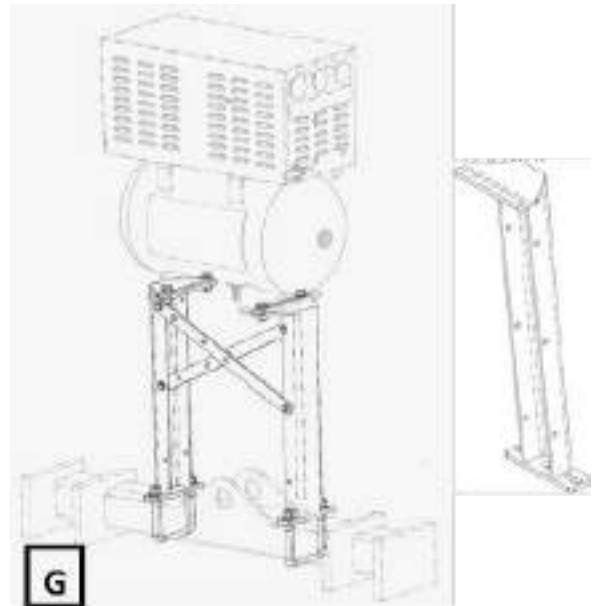

This mounting kit will locate the Compressor low and to the side of the main tongue. Used primarily for Kinze planters to provide clearance under the Lift and Twist transport. Two brackets, two U-bolts, and hardware will be supplied with this kit.

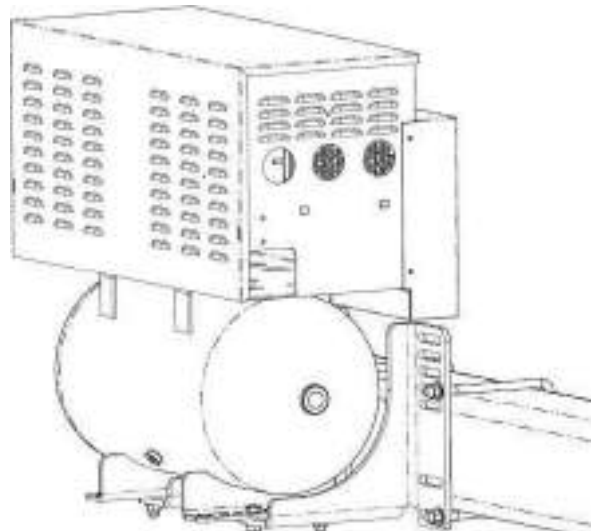

This mounting kit has the same concept as the basic U-bolt, that is adapted for non-standard tubes or channels that comprise the tongue of some planters.

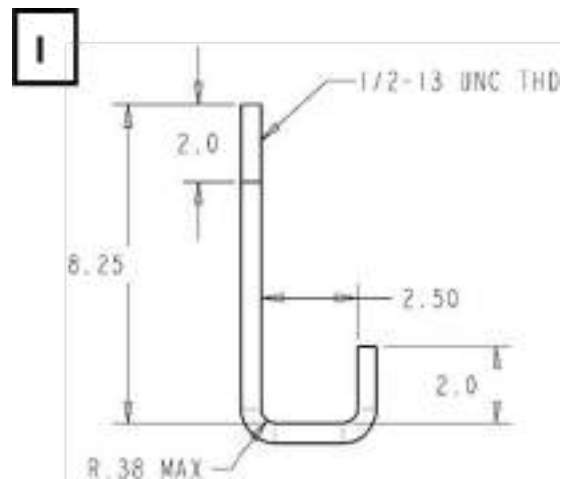

Рекомендации по крутящему моменту

U.S.		Grade 5				Grade 8			
		Dry		Lubricated		Dry		Lubricated	
Bolt Size	Threads Per Inch	Torque (lb-ft)	Torque (N-m)	Torque (lb-ft)	Torque (N-m)	Torque (lb-ft)	Torque (N-m)	Torque (lb-ft)	Torque (N-m)
1/4	20	8	11	6	8	12	16	9	12
5/16	18	17	23	13	18	25	34	18	24
3/8	16	30	41	23	31	45	61	35	47
1/2	13	75	102	55	75	110	149	80	108
5/8	18	180	244	130	176	220	298	170	230

Тестирование системы компрессора CleanSweep

Тест утечки

This leak testing procedure is for the CleanSweep compressor system consisting of a VIAIR 350C electric compressor with 2-gal. tank, regulator control interface, tubing, and cylinders. This procedure shall be performed at the beginning of each season of CleanSweep system use and every 100 hours of in- season use. In addition, it should be performed if the user notices a lack of air pressure availability or if the compressor is running an abnormally high duty cycle. This test will take approximately 10 min. to complete. It will help keep the duty cycle in check, thus extending the life of the compressor

Процедура тестирования системы CleanSweep на утечки

1. Ensure the Tank pressure is above 130 psi and at least 100 psi is in the Lift circuit. If necessary, lower the tank pressure until the compressor turns on and fills the system. This can be done by moving the regulator control lever between Down and Lift. Remember to end with at least 100 psi in the Lift circuit.

2. When Tank pressure drops to a tick mark on the gauge (on the 5's, 130 psi or above), start a stop-watch.
3. Note the pressure drop on the tank gauge in 2 minutes.
4. If the pressure drop is greater than 5 psi, check the Lift and Tank circuits for leaks. Then repair, and test again.
5. Run the above test with at least 100 psi in the Down circuit and repair leaks and retest if necessary.
6. To troubleshoot leak locations, this test may be run with the regulator control lever in the neutral position, thus isolating the test to the Tank circuit.

Тестирование работоспособности компрессора

This health testing procedure is for the CleanSweep compressor system consisting of a VIAIR 350C electric compressor with 2-gal. tank. This procedure shall be performed at the beginning of each season of CleanSweep system use. In addition, it should be performed if the user notices a lack of air pressure availability or if the compressor is running an abnormally high duty cycle. This test will take just a few minutes to complete. It will let the user know if the compressor is in good condition, thus providing adequate pressure supply for the CleanSweep system.

Процедура тестирования работоспособности компрессора

1. Before beginning this test, run the compressor system leak test and ensure it passes. There should be virtually no leaks in the tank circuit before performing this test.
2. Pick a 10-psi range to work in within the range of 125-145 psi (like 130 to 140 psi, for example). This range must be such that the compressor will run throughout.
3. Start tractor if not already running. Test results will be skewed if compressor supply voltage is in-adequate (13.8 VDC no-load recommended).
4. Ensure Tank pressure is below 100 psi. To lower the Tank pressure, move the regulator control lever between Down and Lift to use enough air to drop tank pressure below 100 psi. This step will ensure the compressor turns on and pressure begins building. Stop the regulator control lever in the neutral position (no pressure in Down or Lift).
5. Start a stopwatch when the Tank pressure reaches the lower pressure value in your chosen range.
6. Note the time to build 10 psi in the Tank.
7. If the time recorded is greater than 30 seconds, the compressor is either leaking or is considerably worn. Consider servicing or replacing the compressor before using. If no action is taken and the compressor continues to be used, closely monitor the CleanSweep system pressure availability.

Рекомендации по обслуживанию

- **ЕЖЕДНЕВНО**

1. The water separator inside of the compressor housing needs to be drained DAILY. Also, inspect the system for leaks and repair immediately if found. Leaks in the air lines or fittings will result in dirt being introduced into the system and will decrease cylinder lift significantly.

- **КАЖДЫЕ 100 ЧАСОВ**

1. Drain condensation from the compressor tank.
 2. Remove the air filter pre-cleaner and use compressed air to remove dust and debris. Reinstall.
- **ЕЖЕГОДНО**
 1. Replace the pre-cleaner and air filter on the compressor. Part #726546 includes both the pre-cleaner and the air filter
 2. Perform “Leak Testing” as described in the previous sections.

Работа с системой компрессора CleanSweep

Эксплуатация

The CleanSweep system is energized and ready to operate when the system has 120+ psi of air available. The CleanSweep compressor starts running when the tractor key is turned on and has less than 120 psi in the compressor tank. If sourcing air from the AirForce compressor, the compressor will not run and build air pressure until AirForce is enabled in the 20/20 monitor.

To operate the CleanSweep system, use the cab mounted controller to control the amount of force on the row cleaners.

- **MORE AGGRESSIVE ACTION DESIRED:**
 - Move the control lever to the RIGHT. This will put pressure in the DOWN gauge, effectively adding weight to the row cleaners.
- **LESS AGGRESSIVE ACTION DESIRED:**
 - Move the control lever to the LEFT. This will put pressure in the LIFT gauge, effectively removing weight from the row cleaners.



The amount of down or lift pressure that you use will depend on the specific row cleaners that are on the planter and the field conditions. It is not recommended that the row cleaner be used to move soil. Using a row cleaner for “tillage” or to move soil may result in uneven planting depth.

When unhooking the planter from the tractor, it is advised that the air lines be plugged or capped to prevent dirt and other contaminants from entering the air lines.

Устранение неисправностей

PROBLEM: The compressor will not turn on.

- **Solution:** Check the fuse on the power harness. Replace if necessary.
- **Solution:** Check for power at the 3 pin round connection between the compressor and the power harness. There must be 12v power on pins 1 and 2 (with the tractor key on). Ground is pin 3. If no power, check harnessing for damage. If you have power and ground, move to solution #3.
- **Solution:** Check for operation of the pressure switch and relay. Disconnect the 2 pin WP connector from the pressure switch. Use a jumper wire to connect the 2 pins (this simulates the pressure switch). The compressor should run. If it does run, replace the pressure switch (p/n 755054). If it does not run, replace the relay (part #755095). (This relay is a 12V SPST 50amp Waytek part #75301).

PROBLEM: The compressor never shuts off even though it is at 150+ psi.

- **Solution:** Replace the pressure switch. Part #755054.

PROBLEM: The compressor runs too frequently.

- **Solution:** Check for leaks. Likely there is a loose or broken fitting. Complete the “Leak Testing” from the 100 hour maintenance section of this manual.

PROBLEM: All of the row cleaners do not lift together.

- **Solution:** It is fairly common that all do not lift together. This condition can be normal and should not adversely effect operation in the field. Extreme versions of this situation can be caused by a couple of scenarios. First, the row cleaners could have the pivot points “binding” or pivot point bolts too tight on some rows. All of the row cleaners need to be able to move with the same amount of force, so make adjustments to the row cleaners as necessary to achieve this. Also, check to ensure that the cylinders are installed into the same mounting holes on all rows as the amount of force exerted by the air cylinders is determined by the mounting holes used.

PROBLEM: The control lever is loose, or begins to “creep” under pressure.

- **Solution:** Tighten the lock-nut on the rear of the control box regulator with a 9/16” wrench.

PROBLEM: There is air leaking at the cab-mounted controller when not actively adjusting the row cleaners. (It is normal for air to vent at the controller when making an adjustment).

- **Solution:** Tighten the lock-nut on the rear of the control box regulator with a 9/16” wrench.
- **Solution:** On a new install, check for crossed lines. It is fairly easy to have a line installed incorrectly on one or more rows. The lift circuit must go to the same side of the cylinder on all rows and the down circuit must go to the same side of the cylinder on all rows.
- **Solution:** Check for a leaking cylinder on the planter. To accomplish this, first remove the “lift” air line coming from the planter to the cab control box. Then, move the control lever to the right, placing pressure in the down circuit. There should NOT be air coming through the

“lift” air line that you disconnected. If there is air coming through this line, this indicates one or more row cleaner cylinders are leaking air internally. To narrow down what cylinder(s) are leaking , remove the “up” line from each cylinder and see if air is coming out of the fitting. (this could be the upper or lower connection, depending on what row cleaner and bracket kit is installed) It is recommended that leaking cylinders be replaced as soon as possible. You may be able to temporarily mitigate the leak by adding a small amount of air tool oil to the leaking cylinder. Do not use oil unless a leak is detected as this will wash away the grease seal that the cylinders are originally built with and will ultimately hinder cylinder life. If there is no air leaking in “lift”, reconnect the lift circuit and repeat the above procedure with the down circuit, placing the control lever in lift.

- **Solution:** If all of the above solutions do not remedy the leak, then it is possible that the control box regulator has an internal problem. If this is the case, in solution #3 above, air will be coming from the disconnected control box line. If this is true, replace the control box, part # 755030. You can also replace just the regulator in the control box, however this is not recommended. Part #755078.

Комплект крепежа очистителя рядка и установка пневмоцилиндра



READ BEFORE INSTALLATION!

Installation Overview:

- Prior to installing any new brackets, check the freedom of motion of the row cleaner. It is common for old (and some new) row cleaners to be deformed enough to cause the row cleaner not to pivot freely. Verify that the row cleaner frame is not bound or rubbing against the mounting bracket. It may be beneficial to insert a shim washer on the pivot bolt, between the frame and mounting bracket
- The installation process should be done with the planter raised, half folded for transport, and the row units and row cleaners fully extended down
- Install the Cylinder Base Mounting Bracket

NoteIn some installations, the air cylinder **MUST** be installed prior to installation on the row cleaner because the pin cannot be installed once the row cleaner is installed

- Install and secure the base of the Cylinder into the Cylinder Base Mounting Bracket. Refer to the model specific instructions on the following pages for information on which mounting location to utilize.

NoteBe sure to use the supplied spacer bushings.

- Connect the Cylinder Rod Mounting Bracket to the clevis at the tip of the Cylinder Rod.
- Securing the Cylinder Rod Mounting Bracket:
 - Adjust the Rod Mount Bracket to be centered, or as close to centered as possible, within the clevis yoke. This should align or ‘square’ the cylinder with both mounting brackets and row cleaner frame.
 - There may be considerable slop or play between the clevis yoke and the rod mounting bracket. This is OK and will not negatively affect the performance of the system. This is intended to ease basic installation, especially on mildly deformed row cleaners.
 - Refer to the model specific instructions on the following pages for more information and model specific precautions.
- Adjusting the row cleaner settings:
 - The row cleaner **SHOULD NOT** be allowed to ‘hang’ on the cylinder. First, verify the correct mounting holes were used in mounting the cylinder. Next, adjust the depth stop to ensure that the row cleaner will rest on the depth stop, not on the cylinder.
 - In general, the bottom stop on the row cleaner should not be set lower than what would allow the row cleaner spikes deeper than 1” below seeding depth. This may be confirmed with a tape measure and level or using a 1”X4” board under the opener disc and allowing the spikes to touch the ground.
- **Verify that no specific considerations need to be met for your installation.**

Совместимость с колёсами очистителя рядка

- Not compatible with most NT planters. There is not sufficient clearance in between the transport wheel frames.
- Make sure you have enough clearance between transport frames. With the 3.5" wheels installed, the row cleaner is between 15.5" and 16.5" at its widest point, depending on the specific row cleaner.
- We recommend using treader wheels with CleanSweep. **However, we do not recommend mixing and matching different wheel sizes, so if the 3.5" wheels don't fit your planter, use 1.75" wheels on all rows instead.**
- For Yetter wheels, be sure to align the grease slot on all components. (See Below)

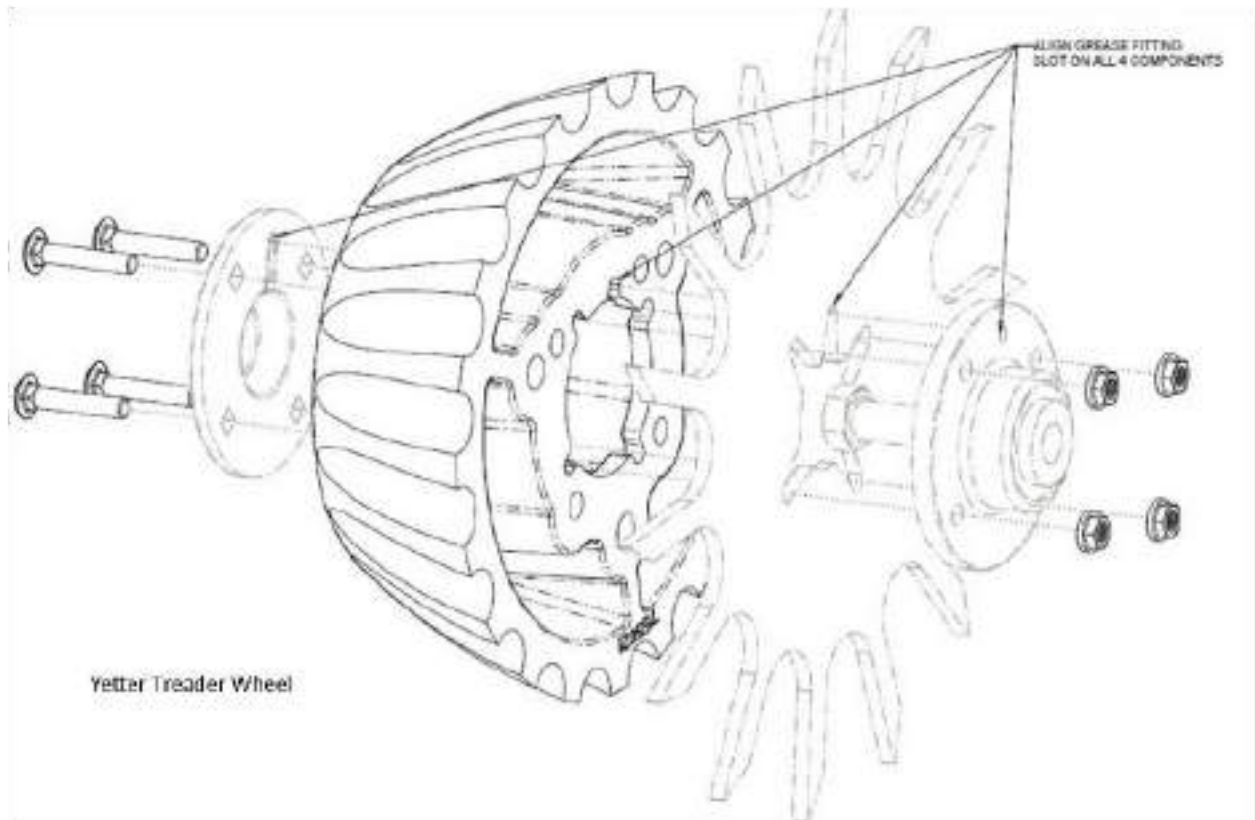

755160 — Yetter Titan 2967-042, 043



Notes and Compatibility Items

JD 7200/7300/17xx

- With Short Parallel Arms and No Coulter: Install spacer block 755209 behind the cylinder base bracket.
- With Long Parallel Arms and No Coulter: Mount using the bottom holes on both rod and base brackets. Flip cylinder upside down, install 1/8" stop kit (755202) and install the spacer block (755209) under the cylinder base bracket.
- With Long Parallel Arms and Coulter (Yetter or Dawn single arm, JD Cast): Mount using the bottom holes on both rod and base brackets. Flip cylinder upside down, install 1/8" stop kit (755202) and install the spacer block (755209) under the cylinder base bracket.

Kit Components

ITEM	QTY	PART NUMBER	PART NAME	DESCRIPTION
1	2	13207	Bolt	1/2"x1.25" GRD5 Bolt ZN
2	2	21826	Bolt, Round Head	1/2"x2" GRD5 ZN Carriage
3	2	37268	Hex Nut	1/2" Top Lock Hex Nut ZN
4	2	37269	Top Lock Jam Nut	1/2" GRD A ZN
5	1	755017	Spacer	5/8" OD x 7/16" ID x 0.688" L
6	1	755019	Pin	Cylinder Rod Pivot
7	2	755028	Cotter Pin	1/8" x 1"
8	1	755147	Bracket	2967-007 Base Mount
9	1	755149	Pin	Cylinder Base Pivot
10	1	755151	Spacer	5/8" OD x 7/16" ID x 0.829" L
11	1	755168	Bracket	2967-042/043 Rod Mount
12	1	755174	Shim	Cylinder Base Mount on 755205
13	1	755203	Air Cylinder	Complete Air Cylinder Assembly (Ordered Sep.)

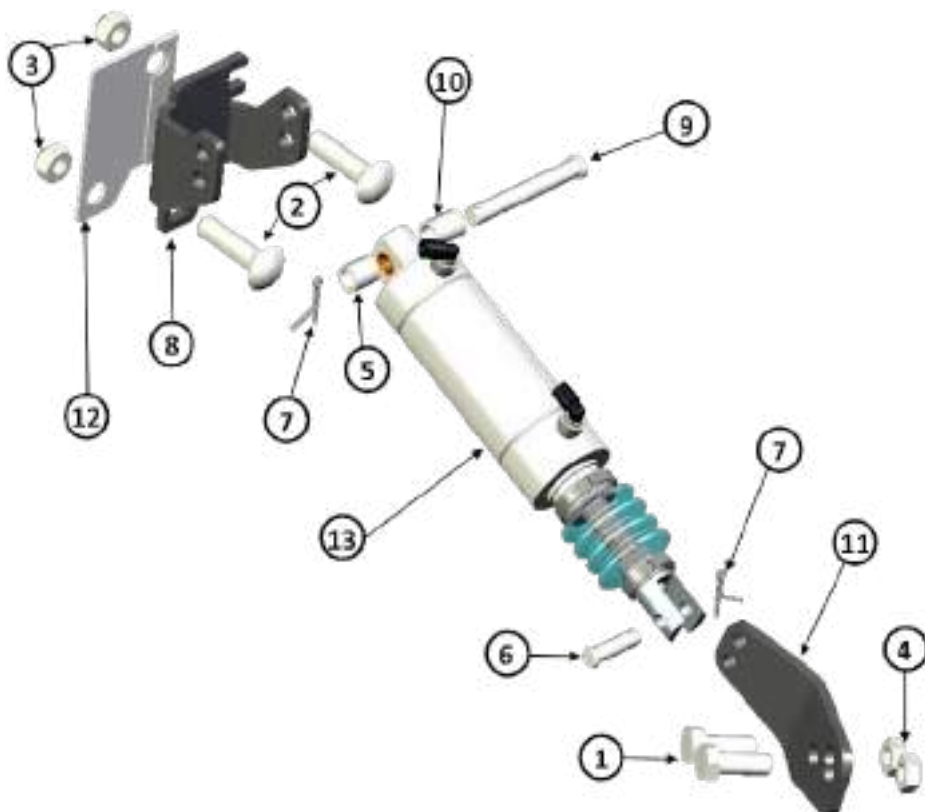

Установка

Шаг 1:

Secure the Cylinder Base Mounting Bracket to the face plate bracket using two - 1/2" X 1.75" carriage bolts and two - 1/2" Top Lock Hex Nuts

Tighten to 75 lb-ft of torque.

Install Shim — 755174 as shown, when JD Cast Coulters is present.

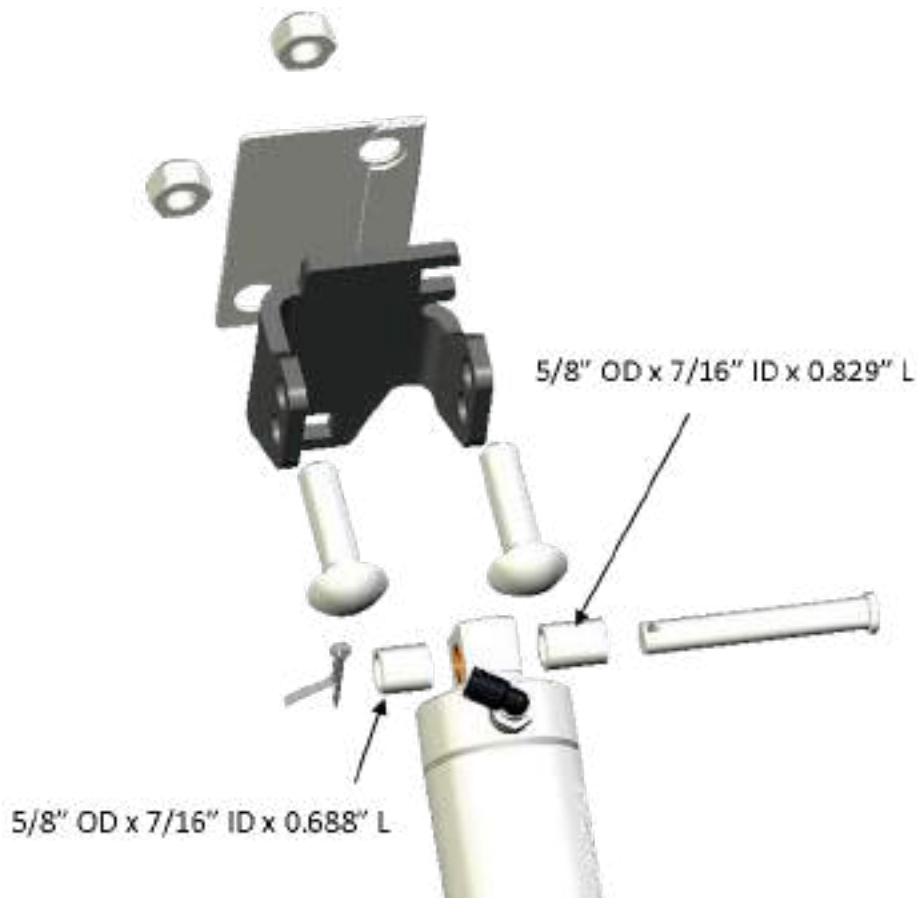

Install the base of the Cylinder to this bracket using the Cylinder Base Pivot Pin (755018). Use the 5/8" OD X 7/16ID X 0.688"L Spacer Bushing (towards the interior of the row) and the 5/8" OD X 7/16ID X 0.829"L Spacer Bushing (towards the exterior of the row) to properly secure and align the cylinder in the Base Mount Bracket.

Refer to the Mounting Hole Selection guide at the end of this section for more information on which mounting holes to use with this bracket. The default pivot hole for cylinder base is the TOP HOLE in the bracket.

Note: When mounting on JD 7200/7300/17XX row units with Long parallel arms (21 inches) the Air Cylinder must be: Installed using the bottom holes on BOTH Rod and Base brackets and installed upside down with the fittings facing the ground.

IIIar 2:

Install the Cylinder Rod Mounting Bracket to the row cleaner frame using the supplied two - 1/2" X 1.25" GRD5 Bolts ZNY, and two - 1/2" GRD A ZN Top Lock Jam Nuts.

Then installing the Cylinder Rod Mount Bracket, be sure it is properly aligned in the clevis yoke of the Rod. This may require the exact angle of the bracket to be tweaked or modified in order to more perfectly match the individual row unit.



Secure the Rod Mounting Bracket to the clevis yoke on the cylinder using the supplied cylinder rod pivot pin (755019) and cotter pin. Refer to the Mounting Hole Selection guide at the end of this section for more information on which mounting holes to use with this bracket.

Then installing the Cylinder Rod Mount Bracket, the first priority is to ensure proper alignment in the clevis yoke of the Rod. There may be considerable slop or play between the clevis yoke and the rod mounting bracket. This is OK and will not negatively affect the performance of the system. This is intended to ease basic installation, especially on mildly deformed row cleaners. Pay close attention to the mounting location of this bracket. Consistent placement from row to row will provide consistent force from row to row and will prevent premature wear on the cylinder. The default pivot hole for the cylinder rod is the TOP HOLE in the bracket.

Verify the freedom of motion and clearance of components. Ensure that the Row Cleaner does not ‘hang’ on the cylinder when extended. This may require extending the row cleaner until this situation is achieved, then selecting the pin location or stop bolt depth just above this depth.

Completed Cylinder Kit Installation

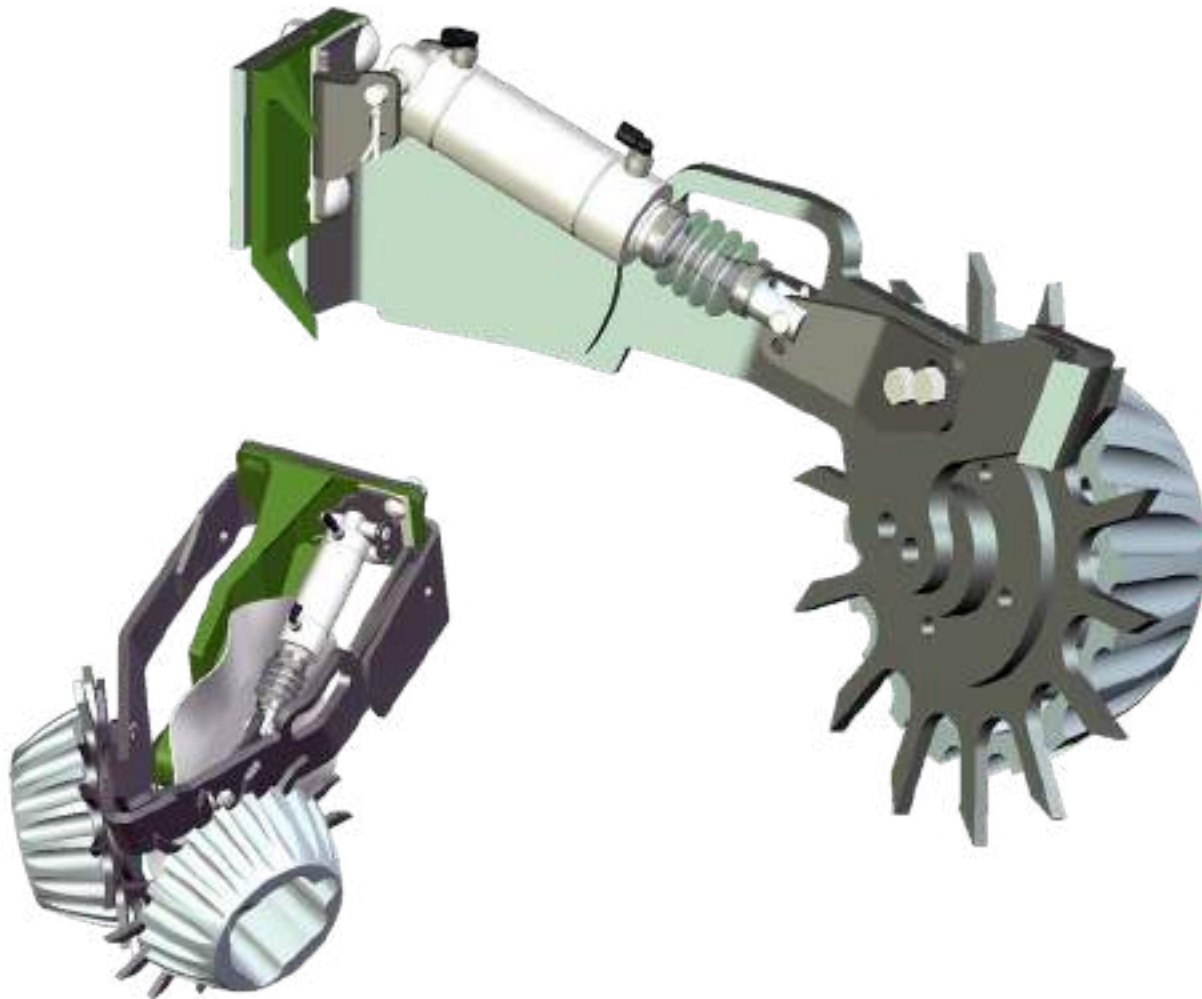

Maintenance Recommendations

If the bellows on the rubber boot become inverted or collapsed, locate the dimple on the rubber boot (near the Cylinder). Pinch the dimple open while articulating the Rod into and out of the Cylinder. This should allow the boot to re-seat properly.

Lubrication: Cylinders are manufactured with a non-migratory grease and should not require additional lubrication under normal operating conditions.

Mounting Hole Selection

Use this page to select the mounting location when using the Yetter 2967–007 Mounting Bracket — 755147

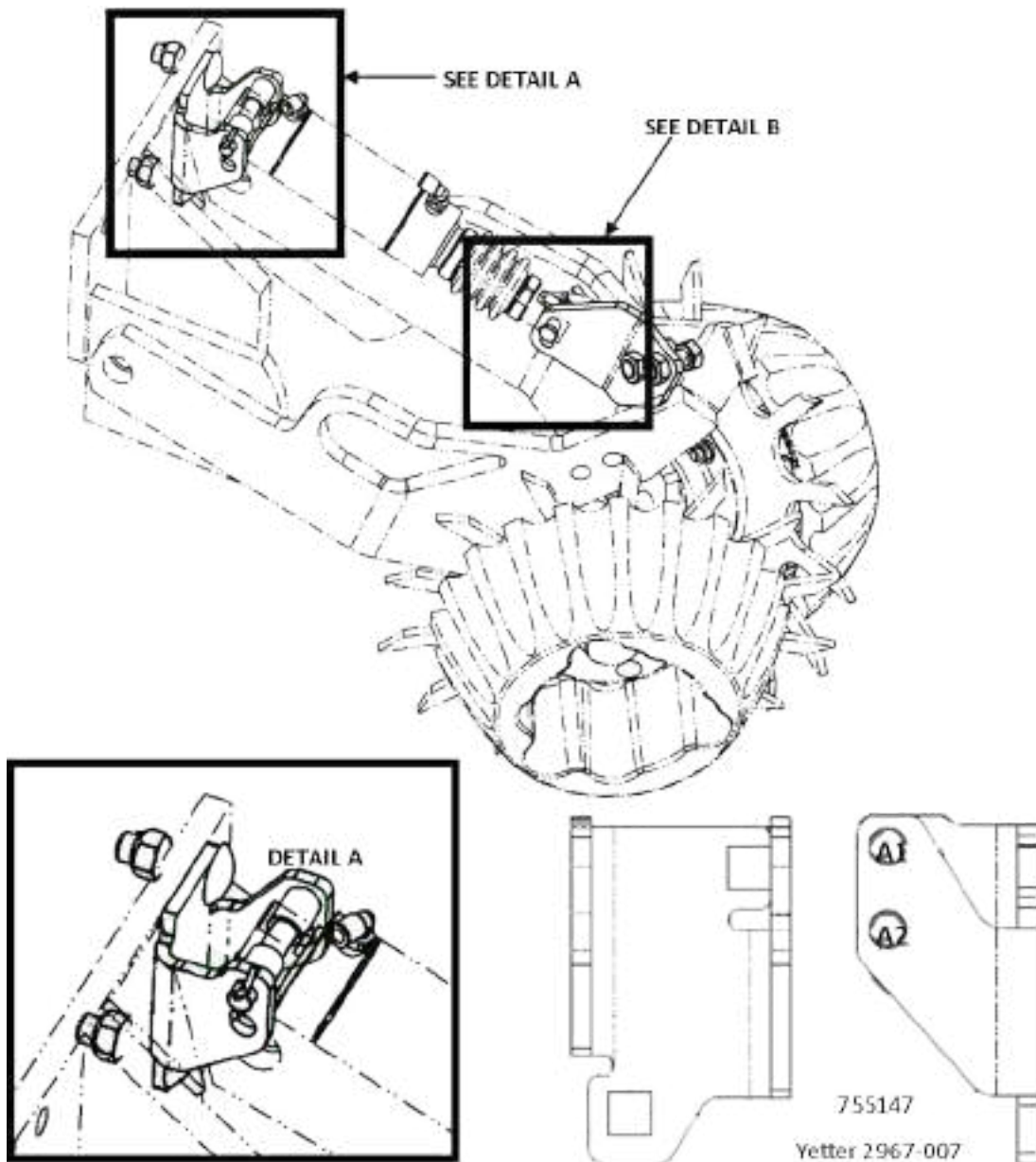

Hole A1 (Top Hole):

- Installing the cylinder in the top holes will INCREASE the magnitude of the force applied to the row cleaner. Therefore;
 - To be used if MORE down force is desired when the system will generally be used in the down direction.
 - To be used if MORE down force is desired when the system will generally be used in the Lift direction.

Hole A2 (Bottom Hole):

- Installing the cylinder in the bottom holes will DECREASE the magnitude of the force applied to the row cleaner. Therefore;

- To be used if LESS down force is desired when the system will generally be used in the down direction.
- To be used if MORE down force is desired when the system will generally be used in the Lift direction.

Note: The hole used on the Rod Mount Bracket should correspond to the same hole used on the Base Mount Bracket. e.g. Top to Top and Bottom to Bottom.

Note: In general, all rows will be set to the same hole. However, some rows may require unique settings. A typical example would be a row unit directly behind a tractor tire. In this example, this row unit should be set to exert more force on the row cleaner than the surrounding rows. If the system is normally operated in LIFT mode, install this row unit in the bottom hole. If the system is normally operated in the DOWN mode, install this row unit in the top hole.



Caution: Risk of hyper-extending the row cleaner/cylinder kit beneath the row unit. DO NOT run the stop bolt too deep. The row cleaner should not be allowed to fall below 38 degrees below horizontal; this usually equates to NO LESS than 3/4" of thread showing on the stop bolt below the stop bolt bracket

755170 — Yetter Titan 2967-115

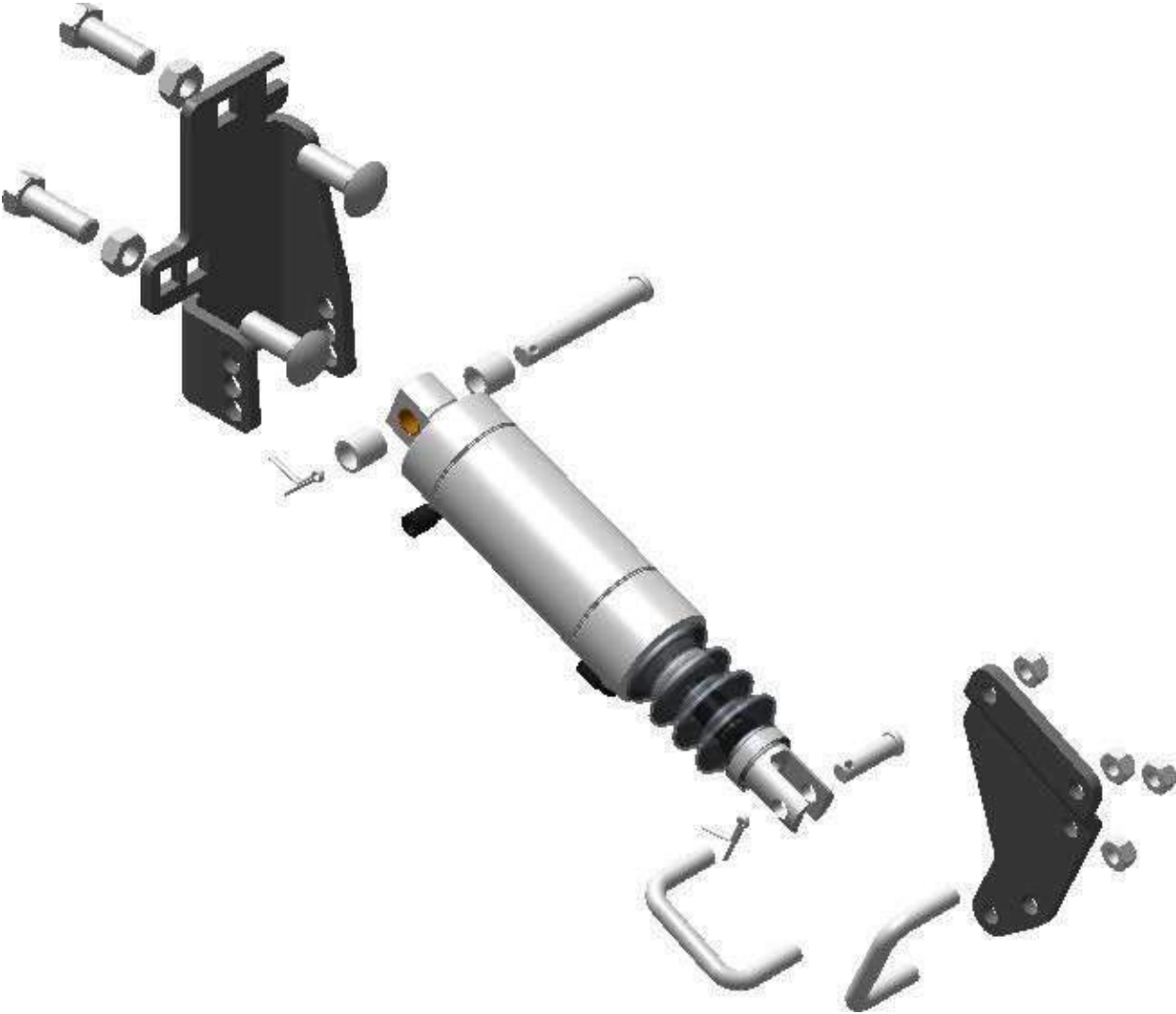

Kit Components

ITEM	QTY	PART NUMBER	PART NAME	DESCRIPTION
1	2	13209	Bolt	1/2"x1.5" GRD5 Bolt ZN
2	2	21824	Bolt, Round Head	1/2"x1.5" GRD5 ZN Carriage
3	4	37264	Hex Nut	3/8" Top Lock Nut ZN
4	2	37268	Hex Nut	1/2" Top Lock Nut ZN
5	2	755017	Spacer	5/8" OD x 7/16" ID x 0.6.88" L
6	1	755018	Pin	Cylinder Base Pivot
7	1	755019	Pin	Cylinder Rod Pivot
8	2	755028	Cotter Pin	1/8" x 1"
9	1	755169	Bracket	2967-115 Base Mount
10	1	755171	Bracket	2967-115 Rod Mount
11	2	755172	U-Bolt	2" x 0.5" Plate
12	1	755203	Air Cylinder	Complete Air Cylinder Assembly (Ordered Sep.)

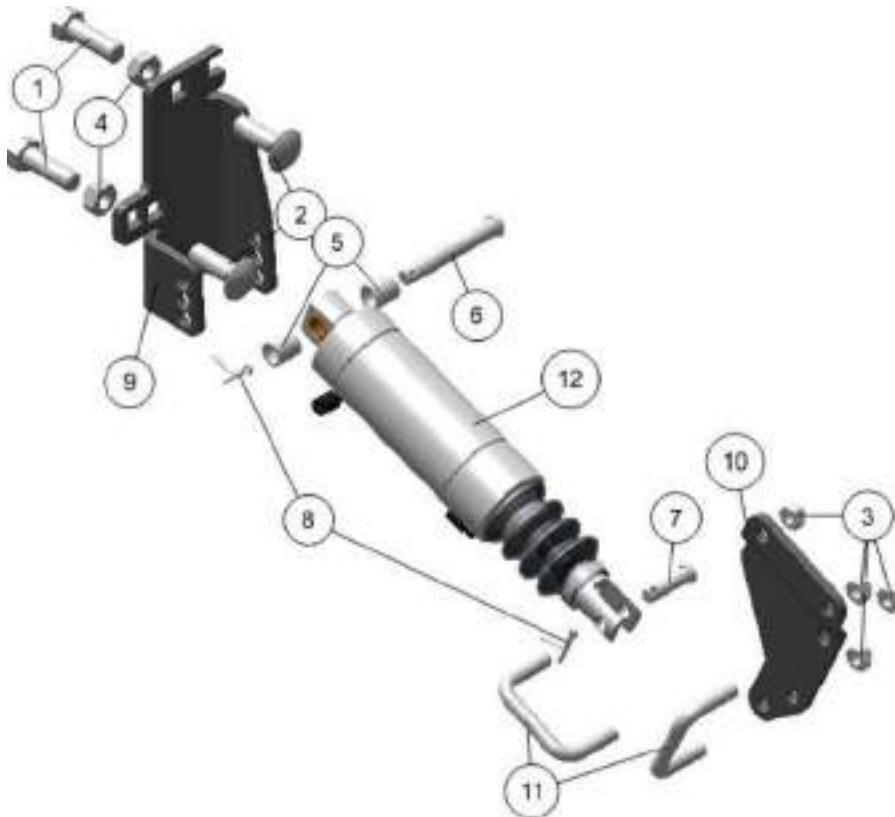

Installation

Step 1:

Secure the Cylinder Base Mounting Bracket to the face plate bracket using two - 1/2" X 1.5" carriage bolts and two - 1/2" Top Lock Hex Nuts or two 1/2" X 1.5" GRD5 Hex Head Bolts and two 1/2" Top Lock Hex Nuts. Both hex head and carriage bolts are included in the hardware pack. Use either style (installed in the direction shown) depending on row cleaner setup to ease installation.



Tighten to 75 lb-ft of torque.

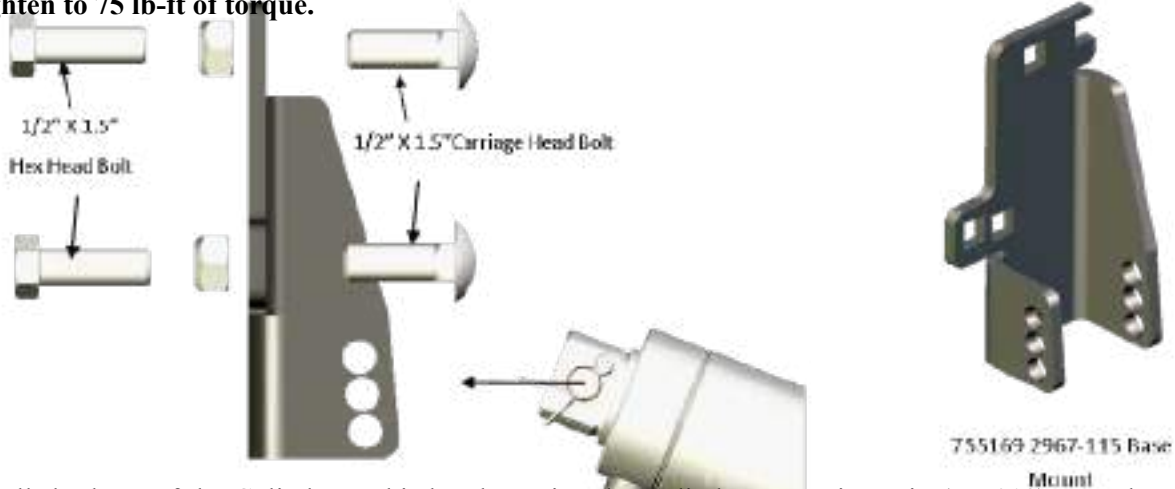

Install the base of the Cylinder to this bracket using the Cylinder Base Pivot Pin (755018). Use the two -5/8" OD X 7/16ID X 0.688"L Spacer Bushings to properly secure and align the cylinder in the Base Mount Bracket

Mount the cylinder base into the 755169 2967-115 Base Mount in the hole that corresponds to the row cleaner pivot. See table below. The default mounting position for the cylinder base will be the top hole.

Position of Row Cleaner Pivot Point	Cylinder Base Mounting Hole
Top Most Position	Top Hole
1/2" Below Top Position	Middle Hole
1" Below Top Position	Bottom Hole

Lift force and down force are reversed on this design. That is, the extend side of the cylinder provides the lift force and the retract side provides the down force. Hence, connect the gray tubes to the extend side of the cylinder (base side) and the black tubes to the retract side (rod side).

Extra hardware is included to ease installation. Choose between using carriage bolts or hex bolts depending on which installs more easily.

Mount cylinder in the hole that corresponds to the position of the row cleaner pivot. E.G: If the row cleaner pivot is in the top most position, use the top hole to mount the cylinder to the base bracket. If the row cleaner is 1/2" below the top position, use the middle hole. If it's 1" below the highest position, use the bottom hole. If it's lower than that use the bottom hole and check to make sure there's clearance around the cylinder (in all functional positions) before using CleanSweep. CleanSweep cannot be used if the row cleaner pivot is lower than 1.5" below the highest position.

Flip the cylinder upside down.

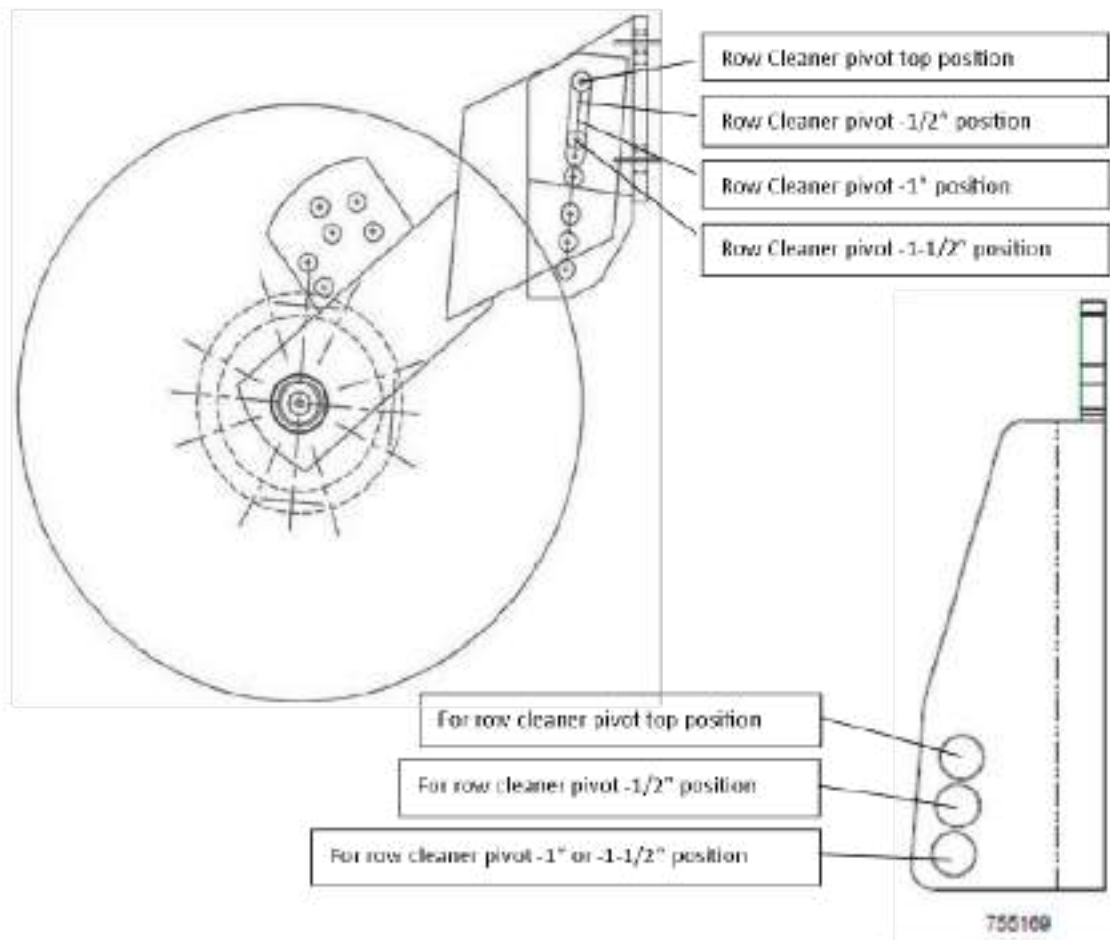

Step 2:

Install the Cylinder Rod Mounting Bracket to the row cleaner frame using the supplied 2" X 1/2" U-bolts (755172) and four - 3/8" Top Lock Hex Nuts (37264). Finger tighten only at this time; DO NOT tighten until the cylinder has been properly aligned.

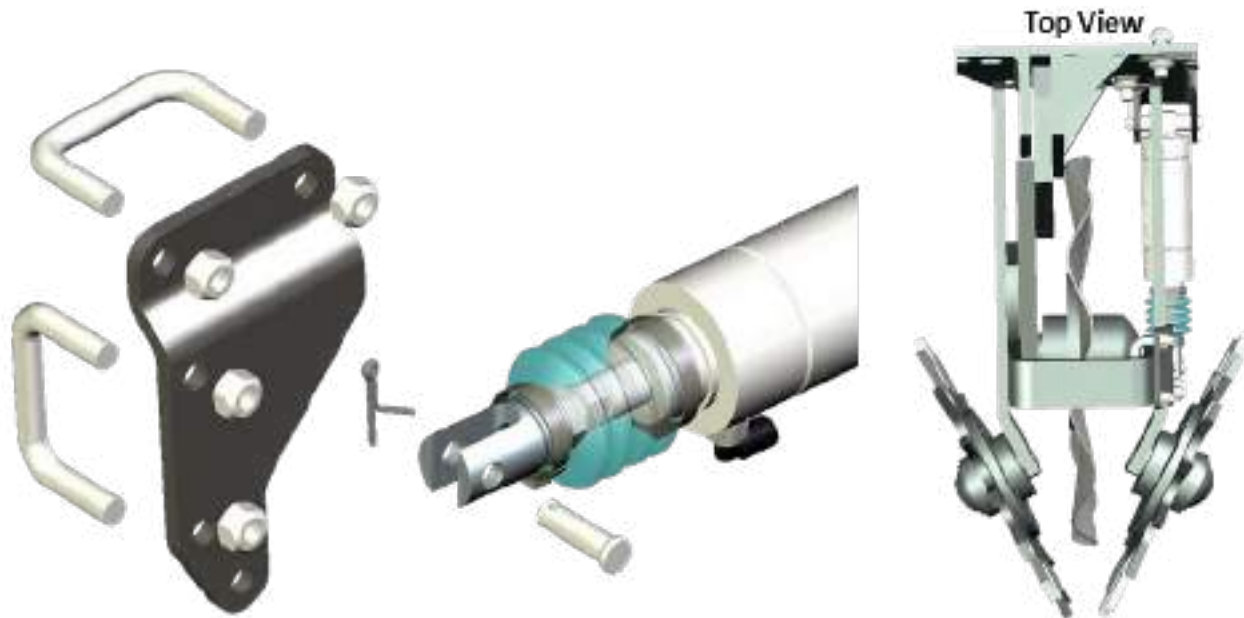

When installing the Cylinder Rod Mount Bracket, the first priority is to ensure proper alignment in the clevis yoke of the Rod. There may be considerable slop or play between the clevis yoke and the rod mounting bracket. This is OK and will not negatively affect the performance of the system. This is inherent in the U-Bolt fastener design and is intended to ease basic installation, especially on mildly deformed row cleaners. Pay close attention to the mounting location of this bracket. Consistent placement from row to row will provide consistent force from row to row and will prevent premature wear on the cylinder.

Secure the Rod Mounting Bracket to the clevis yoke on the cylinder using the supplied cylinder rod pivot pin (755019) and cotter pin.

Once the Rod Mounting Bracket has been properly aligned, secure the bracket by tightening the U-bolts to 30 lb-ft of torque.

Ensure that the Row Cleaner does not 'hang' on the cylinder when extended. This may require extending the row cleaner until this situation is achieved, then selecting the pin location or stop bolt depth just above this depth.

Note: Verify the freedom of motion and clearance of all components.

Completed Cylinder Kit Installation

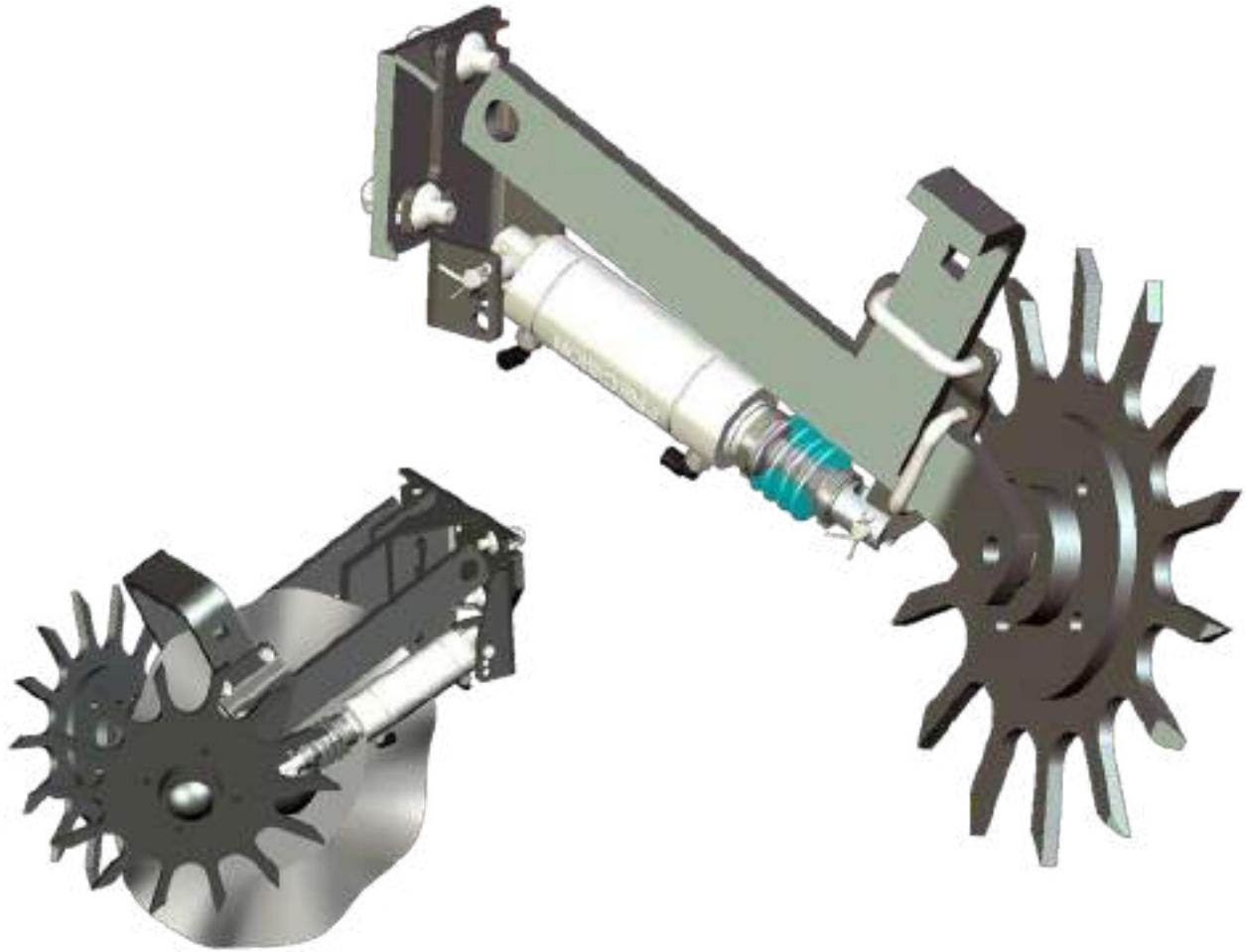

Maintenance Recommendations

If the bellows on the rubber boot become inverted or collapsed, locate the dimple on the rubber boot (near the Cylinder). Pinch the dimple open while articulating the Rod into and out of the Cylinder. This should allow the boot to re-seat properly.

Lubrication: Cylinders are manufactured with a non-migratory grease and should not require additional lubrication under normal operating conditions.

755175 — Yetter Titan 2967-035 (Short Bracket)



Kit Components

ITEM	QTY	PART NUMBER	PART NAME	DESCRIPTION
1	1	13210	Bolt	1/2"x1.75" GRD5 Bolt ZN
2	2	21825	Bolt, Round Head	1/2"x1.75" GRD5 ZN Carriage
3	1	33086	Washer	1/2" SAE Flat Washer ZN
4	2	37264	Hex Nut	3/8" Top Lock Hex Nut ZN
5	2	37268	Hex Nut	1/2" Top Lock Hex Nut ZN
6	1	37273	Top Lock Jam Nut	5/8" GRD A ZN
7	1	755007	U-Bolt	2.75" X 1/2" Plate
8	1	755008	Bracket	MTS Cylinder Base Mount
9	2	755017	Spacer	5/8" OD x 7/16" ID x 0.688" L
10	1	755018	Pin	Cylinder Base Pivot
11	1	755019	Pin	Cylinder Rod Pivot
12	2	755028	Cotter Pin	1/8" X 1"
13	1	755173	Bracket	2967-035 Short Rod Mount
14	1	755023	Air Cylinder	Complete Air Cylinder Assembly (Ordered Sep)

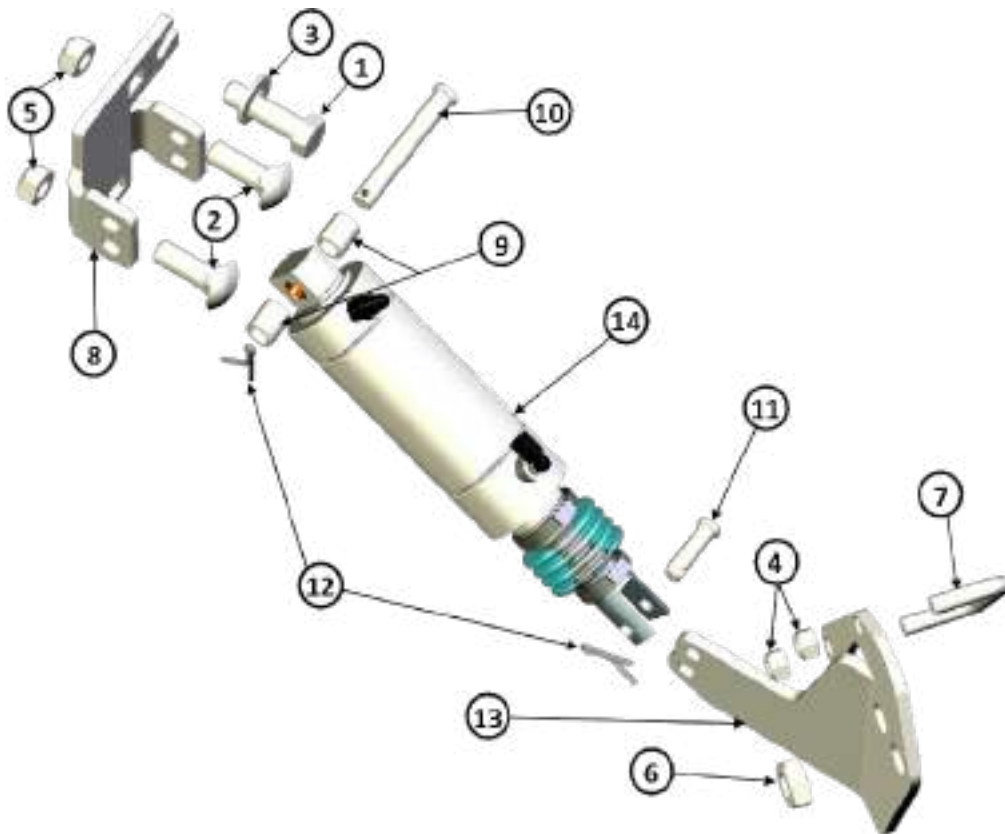

Installation

Step 1:

Secure the Cylinder Base Mounting Bracket to the face plate bracket.

JD 7200/7300/17XX Row Units:

- Mount using two — 1/2" X 1.75" carriage bolts and two — 1/2" top lock hex nuts

JD 7000, Kinze, and White Row Units:

- Mount using one 1/2" X 1.75" carriage bolt, one 1/2" X 1.175" hex head bolt, one 1/2" SAE Flat Washer, and two 1/2" top lock hex nuts.

Tighten to 75 lb-ft of torque.

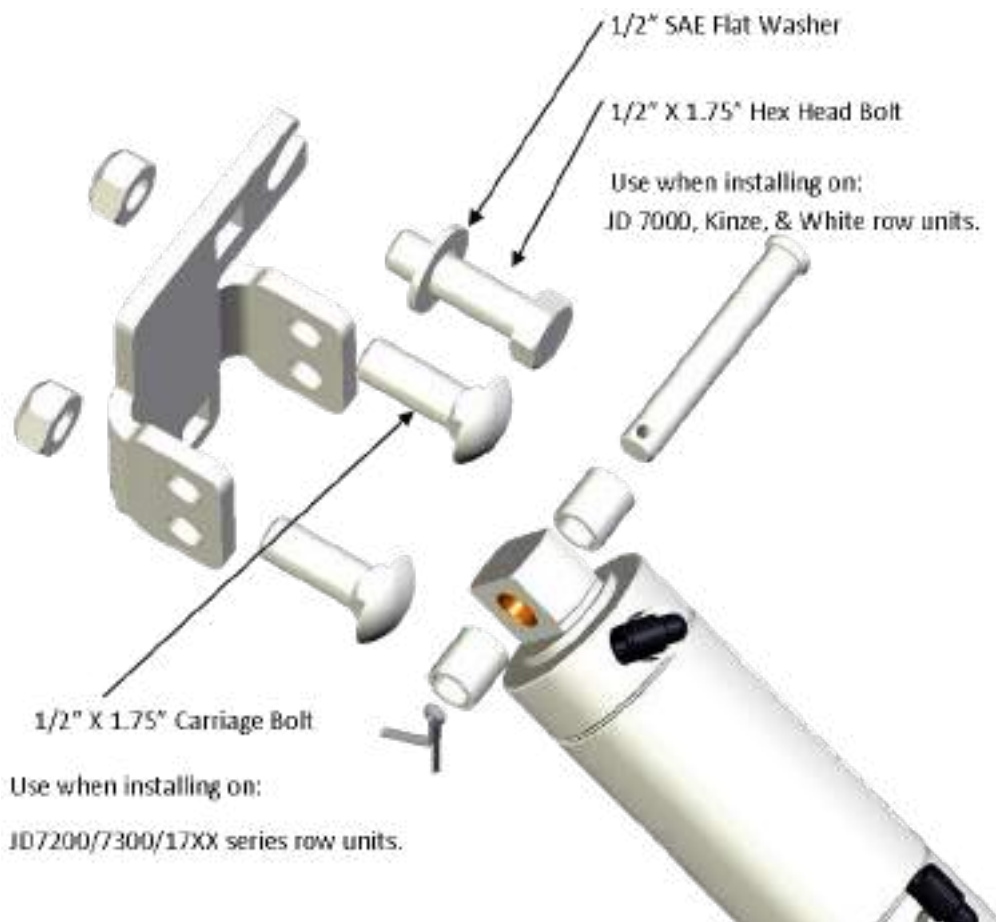

Install the base of the Cylinder to this bracket using the Cylinder Base Pivot Pin (755018). Use the two -5/8" OD X 7/16ID X 0.688"L Spacer Bushings to properly secure and align the cylinder in the Base Mount Bracket.

Refer to the Mounting Hole Selection guide at the end of this section for more information on which mounting holes to use with this bracket. The default pivot hole for the cylinder base is the TOP HOLE of the bracket.

Step 2:

Install the Cylinder Rod Mounting Bracket to the row cleaner frame using the supplied 2.75" X 1/2" U-bolt (755007), two - 3/8" Top Lock Hex Nuts (37264) and one - 5/8" Top Lock Hex Nut. This install will require the removal of the nut and washer present on the D-Bolt (serving as the axle) of the row cleaner. Re-install using the supplied 5/8" Nut and using the Mounting Bracket in place of the washer. Ensure proper alignment of all components, and that the hub is secured and returned to manufacturer's recommendations.

Do not tighten until the cylinder has been properly aligned.

When installing the Cylinder Rod Mount Bracket, be sure it is properly aligned in the clevis yoke of the Rod. *This may require the exact angle of the bracket to be tweaked or modified* in order to more perfectly match the individual row unit.

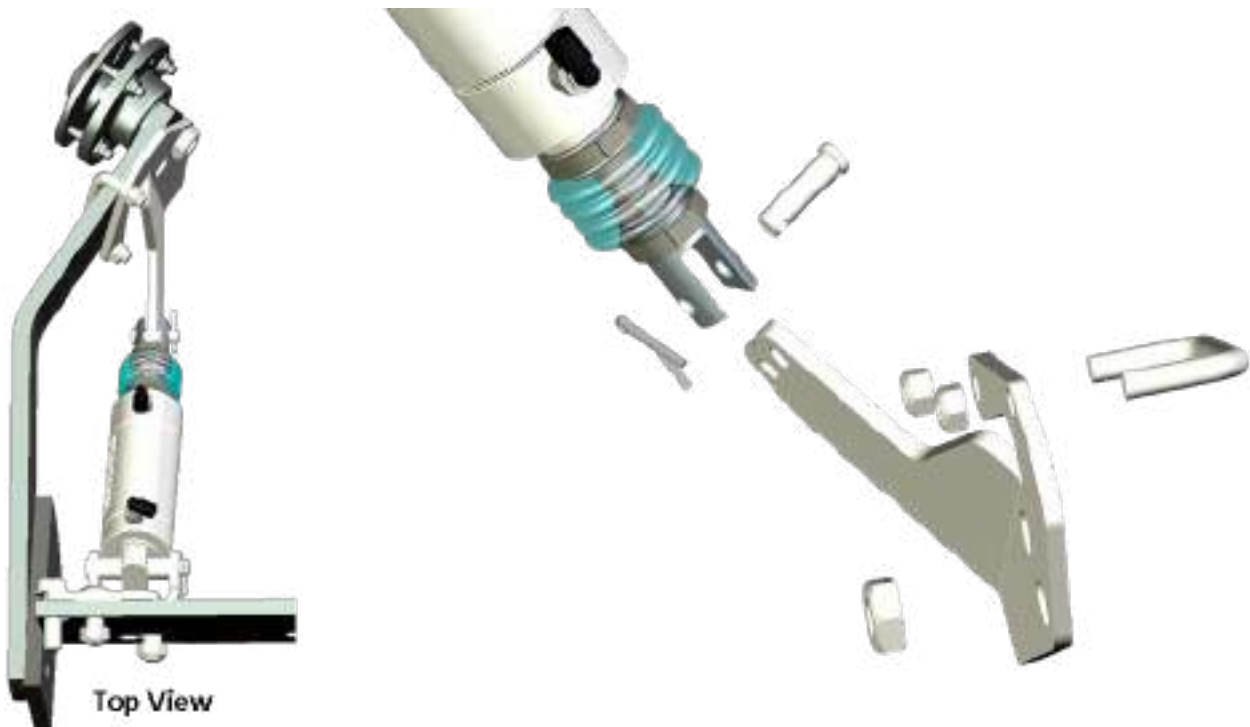

Secure the Rod Mounting Bracket to the clevis yoke on the cylinder using the supplied cylinder rod pivot pin (755019) and cotter pin. Refer to the Mounting Hole Selection guide at the end of this section for more information on which mounting holes to use with this bracket.

When installing the Cylinder Rod Mount Bracket, the first priority is to ensure proper alignment in the clevis yoke of the Rod. There may be considerable slop or play between the clevis yoke and the rod mounting bracket. This is OK and will not negatively affect the performance of the system. This is intended to ease basic installation, especially on mildly deformed row cleaners. Pay close attention to the mounting location of this bracket. Consistent placement from row to row will provide consistent force from row to row and will prevent premature wear on the cylinder. The default pivot hole for the cylinder rod is the TOP HOLE of the bracket.

Verify the freedom of motion and clearance of components.

Ensure that the Row Cleaner does not ‘hang’ on the cylinder when extended. This may require extending the row cleaner until this situation is achieved, then selecting the pin location or stop bolt depth just above this depth.

Completed Cylinder Kit Installation

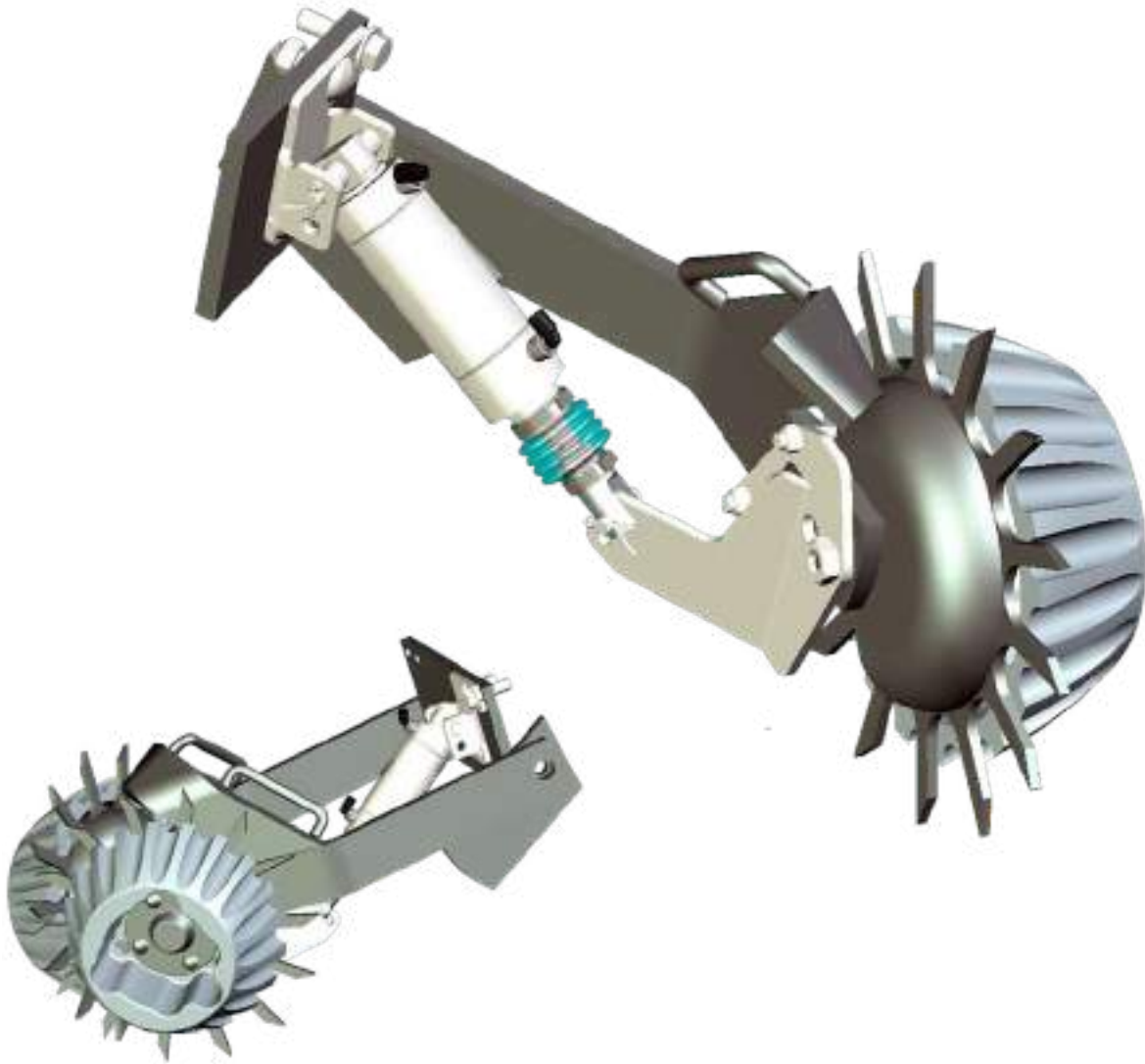

Maintenance Recommendations

If the bellows on the rubber boot become inverted or collapsed, locate the dimple on the rubber boot (near the Cylinder). Pinch the dimple open while articulating the Rod into and out of the Cylinder. This should allow the boot to re-seat properly.

Lubrication: Cylinders are manufactured with a non-migratory grease and should not require additional lubrication under normal operating conditions.

Mounting Hole Selection: 2967–035 (Short Frame)

Use this page to select the mounting location when using the Mounting Bracket — 755008

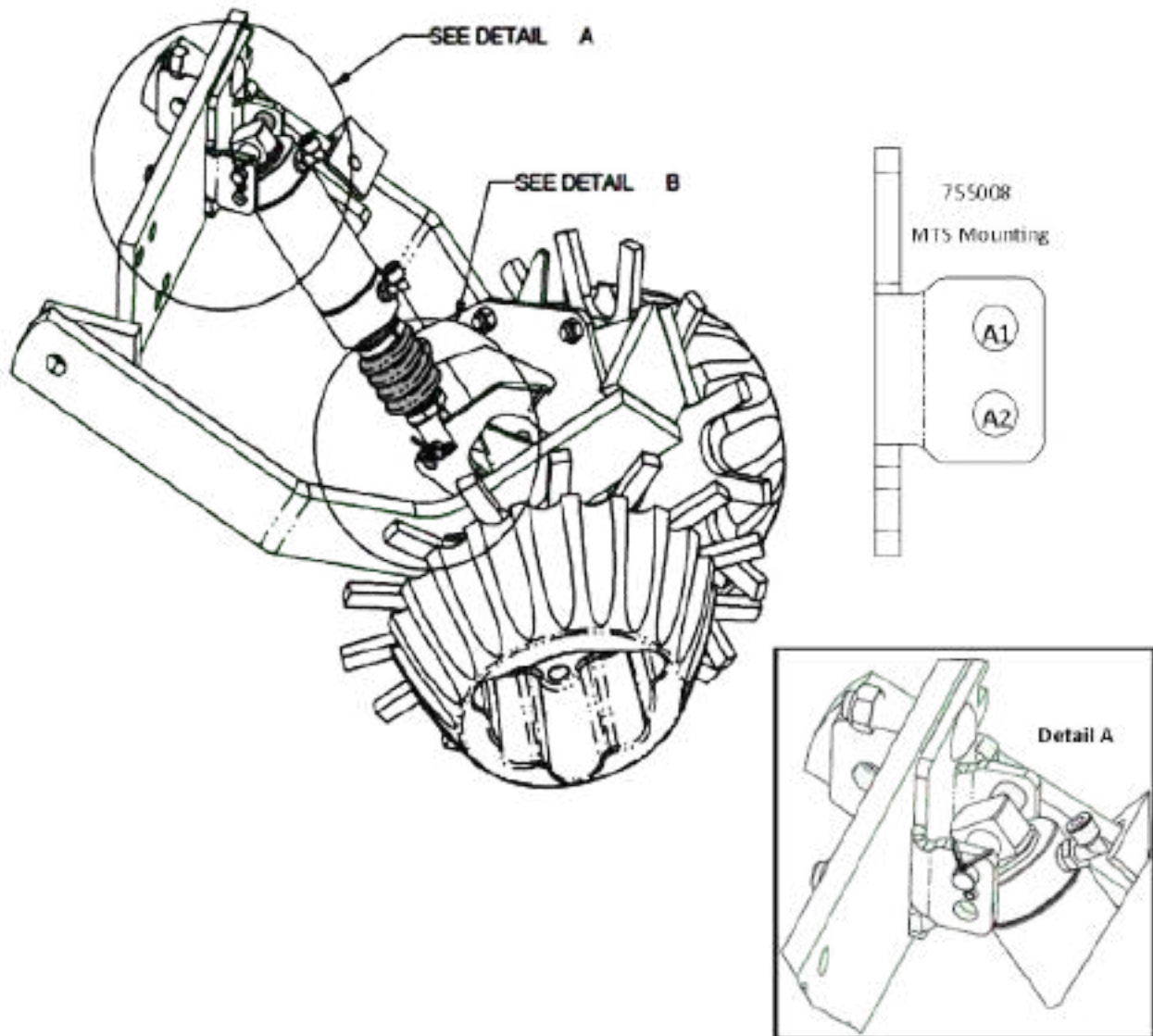

Hole A1 (Top Hole):

- Installing the cylinder in the top holes will INCREASE the magnitude of the force applied to the row cleaner. Therefore;
 - To be used if MORE down force is desired when the system will generally be used in the down direction.
 - To be used if MORE down force is desired when the system will generally be used in the Lift direction.

Hole A2 (Bottom Hole):

- Installing the cylinder in the bottom holes will DECREASE the magnitude of the force applied to the row cleaner. Therefore;
 - To be used if LESS down force is desired when the system will generally be used in the down direction.
 - To be used if MORE down force is desired when the system will generally be used in the Lift direction.

Note: The hole used on the Rod Mount Bracket should correspond to the same hole used on the Base Mount Bracket. e.g. Top to Top and Bottom to Bottom.

Note: In general, all rows will be set to the same hole. However, some rows may require unique settings. A typical example would be a row unit directly behind a tractor tire. In this example, this row unit should be set to exert more force on the row cleaner than the surrounding rows. If the system is normally operated in LIFT mode, install this row unit in the bottom hole. If the system is normally operated in the DOWN mode, install this row unit in the top hole.



Caution: Risk of hyper-extending the row cleaner/cylinder kit beneath the row unit. DO NOT run the stop bolt too deep. The row cleaner should not be allowed to fall below 38 degrees below horizontal; this usually equates to NO LESS than 3/4" of thread showing on the stop bolt below the stop bolt bracket

755180 — Yetter Titan 2967-035



Notes and Compatibility Items

JD 7200/7300/17XX

- With regular parallel arms (14") and chain drive: If JD cast coupler is installed, optional shim (755159) may be necessary to help align the cylinder brackets. For UMO compatibility, see Table 2 in Appendix A.
- With regular parallel arms (14") and pro drive, JD Cast Coupler, Yetter, or Dawn single arm couler: JD Mount using bottom holes of the rod and base brackets, flip cylinder upside down. If JD cast coupler is installed, optional shim (755159) may be necessary to help align the cylinder brackets. For UMO compatibility, see Table 2 in Appendix A.

- With long parallel arms (21") and no coulters, JD cast coulters with treader wheels, Yetter single arm or Dawn single arm coulters with treader wheels: Mount using bottom holes on both rod and base brackets, flip cylinder upside down, and install 1/8" stop kit (755202). Shim (755159) installed under the cylinder base bracket may be necessary to help align the cylinder brackets with JD cast coulters.
- With long parallel arms (21") and JD Cast Coulters, Yetter single arm coulters or Dawn single arm coulters without treader wheels: Mount using bottom holes on both rod and base brackets, flip cylinder upside down, and install 1/4" stop kit (726530). Shim (755159) installed under the cylinder base bracket, may be necessary to help align the cylinder brackets with JD Cast Coulters.

Kinze

- With Kinze Double Arm Coulters: Kinze coulters bracket must be significantly modified in order to make the base bracket fit. (See Knowledge Base article #49 for details).

White 9000

- Mount using bottom holes on both rod and base brackets.

Kit Components

ITEM	QTY	PART NUMBER	PART NAME	DESCRIPTION
1	2	21826	Carriage Bolt	1/2"x 2" Round Head Bolt
2	2	37264	Hex Nut	3/8" Top Lock Hex Nut ZN
3	2	37268	Hex Nut	1/2" Top Lock Hex Nut ZN
4	1	37272	Hex Nut	5/8" Top Lock Hex Nut ZN
5	1	755004	Bracket	MTR Cylinder Base Mount
6	1	755007	U-Bolt	2.75" x 1/2" Plate
7	2	755017	Spacer	5/8" OD x 7/16 ID x 0.688" L
8	1	755018	Pin	Cylinder Base Pivot
9	1	755019	Pin	Cylinder Rod Pivot
10	1	755022	Rod Mount	Titan Rod Mount
11	1	755023	Air Cylinder	Complete Air Cylinder Assembly (sold sep)
12	2	755028	Cotter Pin	1/8" X 1"

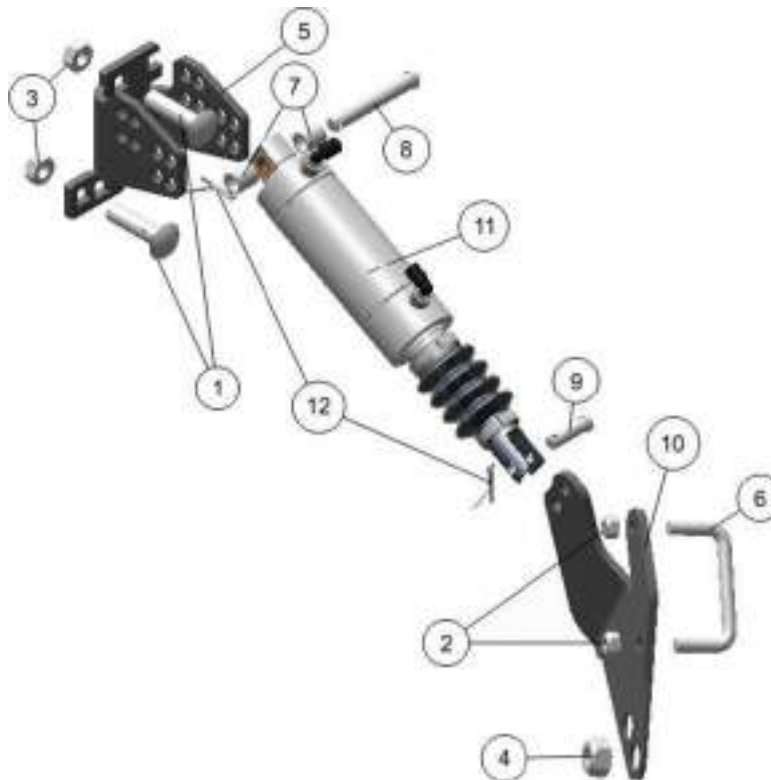

Installation

Step 1:

Secure the Cylinder Base Mounting Bracket to the face plate bracket using two — 1/2" x 1.75" carriage bolts and two — 1/2" Top Lock Hex Nuts.

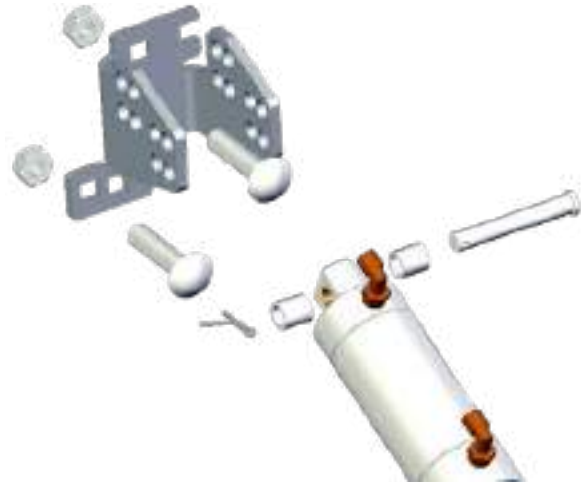

Tighten to 75 lb-ft of torque.

Install the base of the Cylinder to this bracket using the Cylinder Base Pivot Pin (755018). Use the two — 5/8" OD x 7/16" ID x 0.688" L Spacer Bushings to properly secure and align the cylinder Base Mount Bracket.

Refer to the Mounting Hole selection guide at the end of this section for more information on which mounting holes to use with this bracket.

Step 2:

Install the Cylinder Rod Mounting Bracket to the row cleaner frame using the supplied 2.75" X 1/2" U-bolts (755007), two - 3/8" Top Lock Hex Nuts (37264) and one - 5/8" Top Lock Hex Nut. This install will require the removal of the nut and washer present on the D-Bolt (serving as the axle) of the row cleaner. Re-install using the supplied 5/8" Nut and using the Mounting Bracket in place of the washer. Do not tighten until the cylinder has been properly aligned. When installing the Cylinder Rod Mount Bracket, be sure it is properly aligned in the clevis yoke of the Rod. *This may require the exact angle of the bracket to be tweaked or modified* in order to more perfectly match the individual row unit.

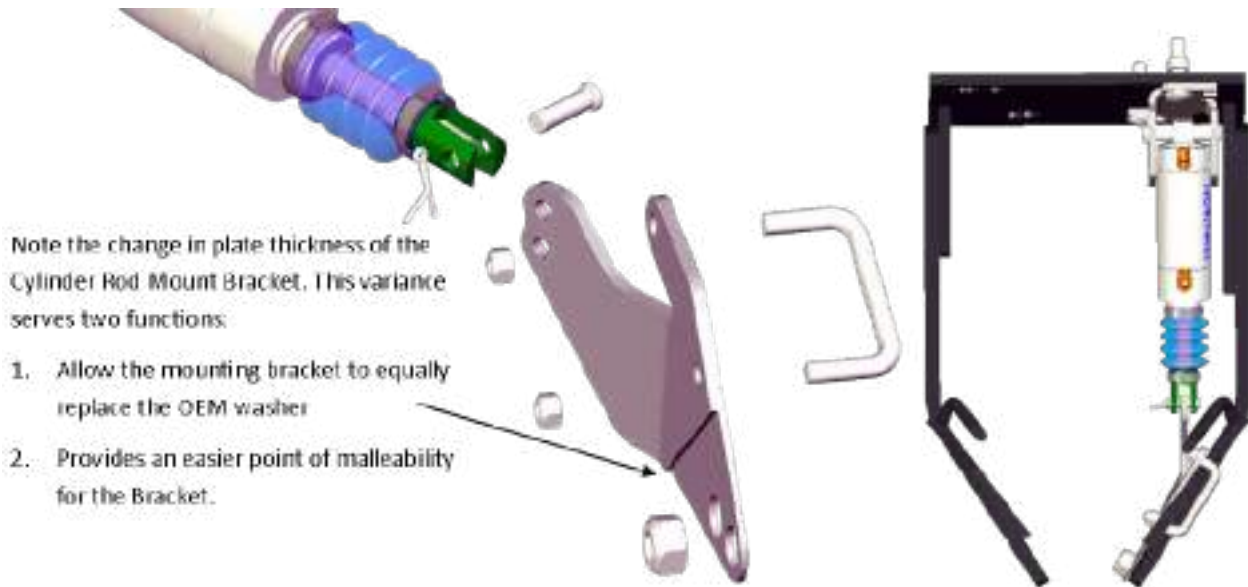

Secure the Rod Mounting Bracket to the clevis yoke on the cylinder using the supplied cylinder rod pivot pin (755019) and cotter pin. Refer to the Mounting Hole Selection guide at the end of this section for more information on which mounting holes to use with this bracket.

When installing the Cylinder Rod Mount Bracket, the first priority is to ensure proper alignment in the clevis yoke of the Rod. There may be considerable slop or play between the clevis yoke and the rod mounting bracket. This is OK and will not negatively affect the performance of the system. This is intended to ease basic installation, especially on mildly deformed row cleaners. Pay close attention to the mounting location of this bracket. Consistent placement from row to row will provide consistent force from row to row and will prevent premature wear on the cylinder. The default pivot hole for the cylinder rod is the TOP HOLE of the bracket.

Verify the freedom of motion and clearance of components.

Ensure that the Row Cleaner does not 'hang' on the cylinder when extended. This may require extending the row cleaner until this situation is achieved, then selecting the pin location or stop bolt depth just above this depth.

Completed Cylinder Kit Installation

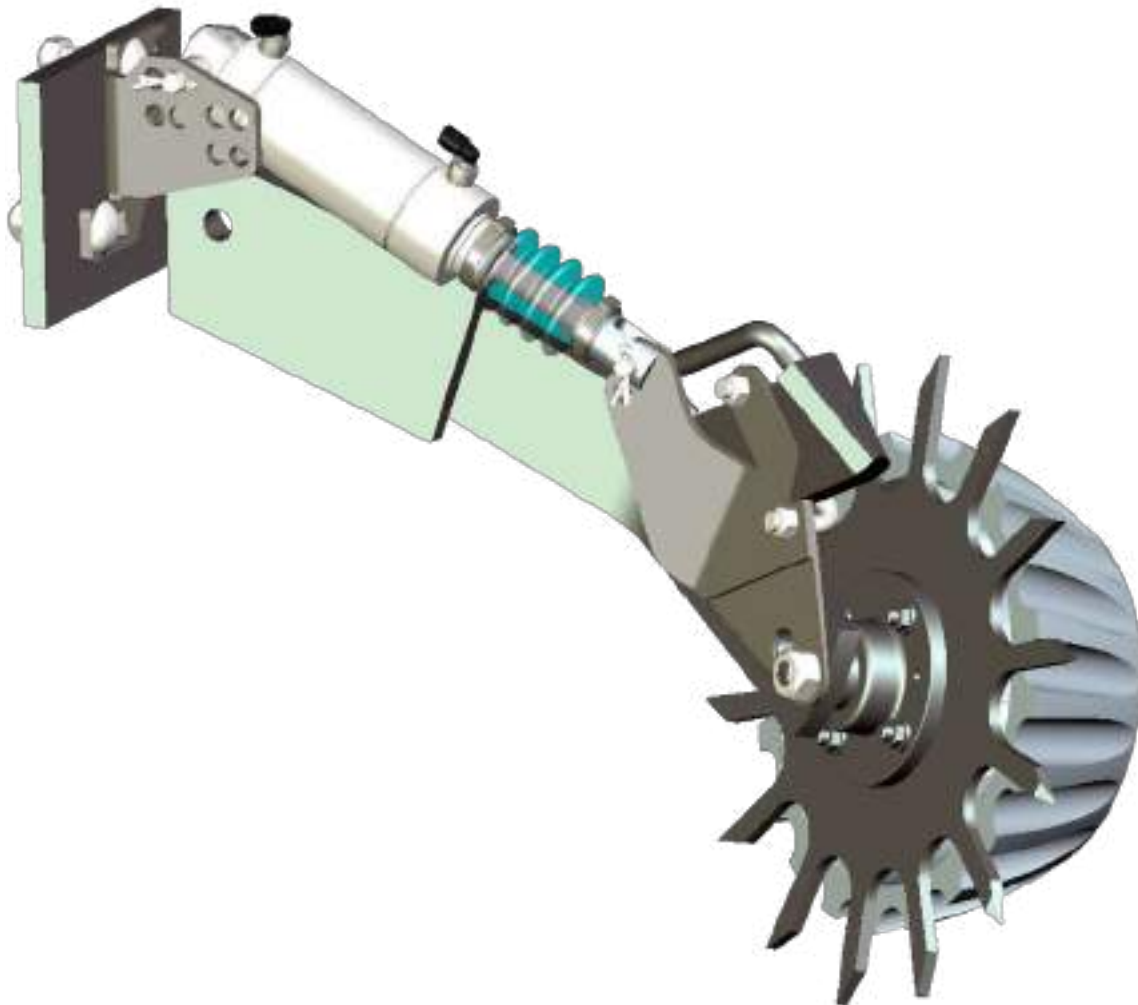

Maintenance Recommendations

If the bellows on the rubber boot become inverted or collapsed, locate the dimple on the rubber boot (near the Cylinder). Pinch the dimple open while articulating the Rod into and out of the Cylinder. This should allow the boot to re-seat properly.

Lubrication: Cylinders are manufactured with a non-migratory grease and should not require additional lubrication under normal operating conditions.

Mounting Hole Selection: 2967-035 (Short Frame)

Use this page to select the mounting location when using the Mounting Bracket — 755008

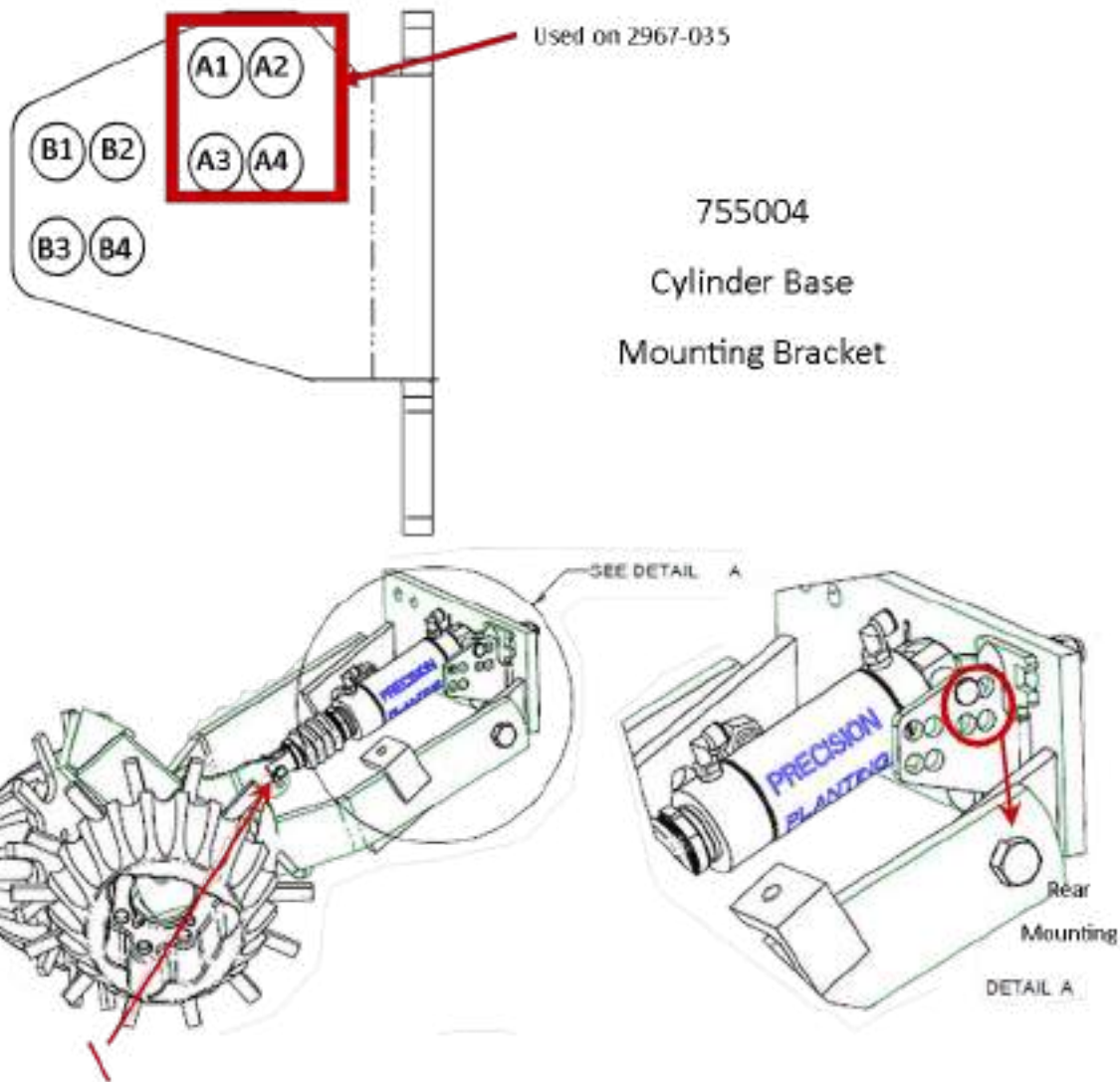

The hole used on the Rod Mount Bracket should correspond to the same hole used on the Base Mount Bracket. Example: Top to Top and Bottom to Bottom

A Range Holes:

- To be used with Yetter Titan 2967-035 and Martin MTR when the row cleaner frame pivots in the rear holes.

Holes 1 and 2 (Top Holes):

- Installing the cylinder in the top holes will INCREASE the magnitude of the force applied to the row cleaner. Therefore;
 - To be used if MORE down force is desired when the system will generally be used in the down direction.
 - To be used if LESS down force is desired when the system will generally be used in the Lift direction.

Note Not to be used with Long Parallel Arms or JD 7000 row units.

Holes 3 and 4 (Bottom Holes):

- Installing the cylinder in the bottom holes with DECREASE the magnitude of the force applied to the row cleaner. Therefor;
 - To be used if LESS down force is desired when the system will generally be used in the down direction.
 - To be used if MORE down force is desired when the system will generally be used in the lift direction.

Holes 1 and 3 (Front Holes):

- To be used if bracket is mounted directly to the row cleaner face plate bracket.

Holes 2 and 4 (Rear Holes):

- To be used if bracket is mounted on top of another attachment. (Row unit mounted coulter, UMO 100 etc.)

Note: In general, all rows will be set to the same hole. However, some rows may require unique settings. A typical example would be a row unit directly behind a tractor tire. In this example, this row unit should be set to exert more force on the row cleaner than the surrounding rows. If the system is normally operated in LIFT mode, install this row unit in the bottom hole. If the system is normally operated in the DOWN mode, install this row unit in the top hole.



Caution: Risk of hyper-extending the row cleaner/cylinder kit beneath the row unit. DO NOT run the stop bolt too deep. The row cleaner should not be allowed to fall below 38 degrees below horizontal; this usually equates to NO LESS than 3/4" of thread showing on the stop bolt below the stop bolt bracket

Installation Notes

Row Unit: JD 7200 with Reg. or Long Parallel Arms w/ JD Coulter

If a JD Cast Iron Coulter frame is installed, the draft angle of the cast iron bracket may lead to the misalignment of the two cylinder mounting brackets. If the misalignment is so severe that the cylinder cannot be installed freely, install the 755159 shim directly behind the cylinder base mounting bracket.

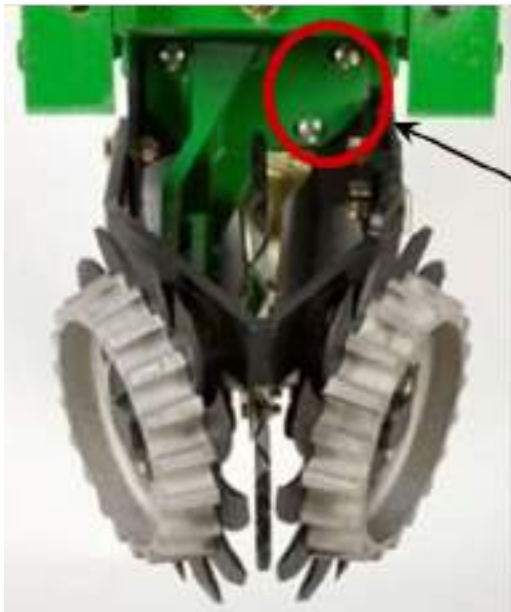

755159 Shim



755185 — Yetter Titan 2967-007

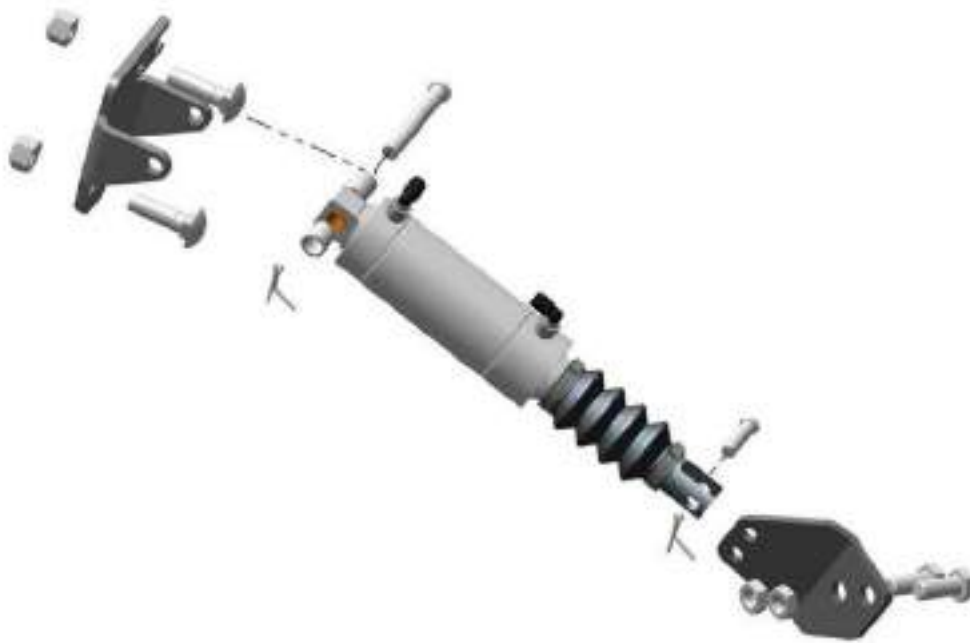

Notes and Compatibility Items

JD 7200/7300/17XX

-

- With long parallel arms (21"): Mount using bottom holes on both rod and base brackets, flip cylinder upside down, and install 1/8th stop blocks (755202).

White 9000 with Pneumatic Down Force

- Mount using bottom holes on both rod and base brackets. Flip cylinder upside down.

Kit Components

ITEM	QTY	PART NUMBER	PART NAME	DESCRIPTION
1	2	21825	Bolt	1/2"- 13 x 1.5" GRD 5 Carriage
2	1	33090	Washer	5/8" SAE Flat ZN
3	2	37268	Hex Nut	1/2"-13 GRD A ZN
4	2	37269	Jam Nut	1/2"-13 GRD A ZN
5	2	95207	Bolt	1/2"-13 X 1.25" GRD 5 Bolt ZN
6	1	755017	Spacer	5/8 OD X 7/16 ID X .688
7	1	755019	Pin	Cylinder Rod Pivot
8	1	755023	Air Cylinder	Complete Assembly (Sold Sep.)
9	2	755028	Cotter Pin	1/8" X 1"
10	1	755148	Bracket	2967-007 Rod Mount
11	1	755149	Pin	Cylinder Base Pivot
12	1	755151	Spacer	5/8" OD X 7/16" ID X .829
13	1	755228	Bracket	2967-007 Base Mount

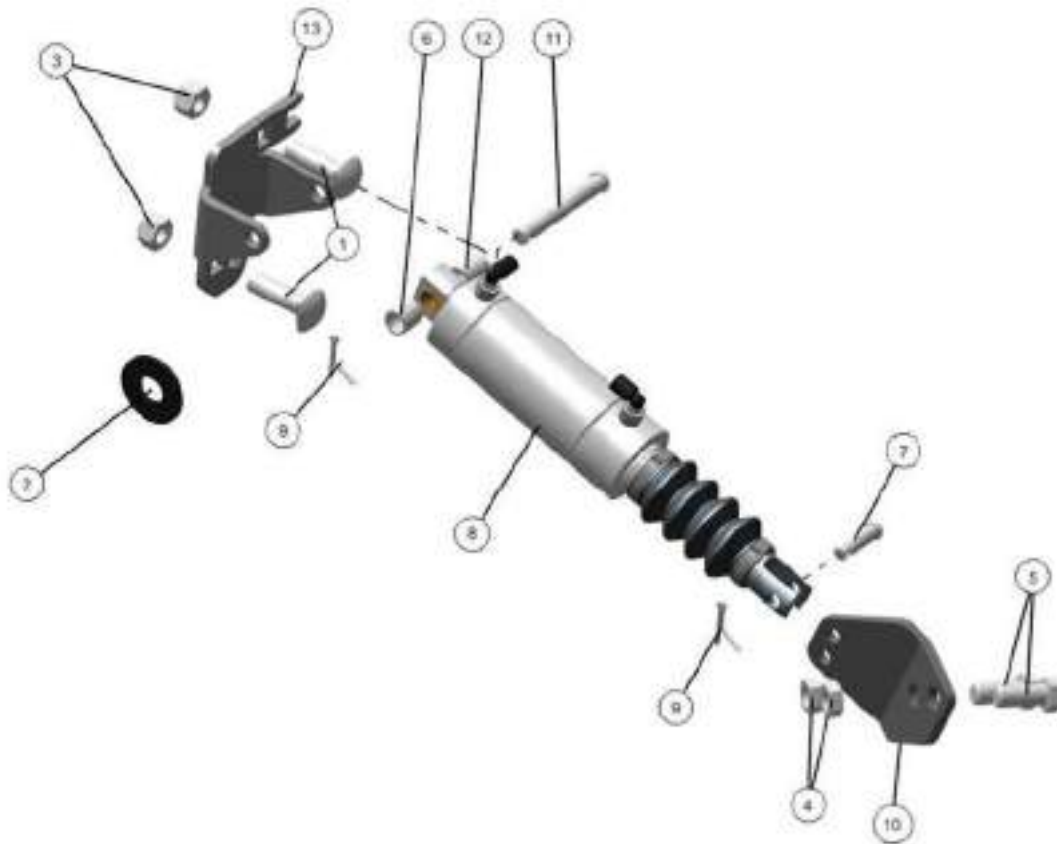

Installation

Step 1:

This installation requires the removal of the plate shown in the figures below. This plate will cause clearance issues with the cylinder. The parts kit includes a 5/8" washer, part number 33090. This washer is used to replace the spacer that was previously installed with the plate that was removed.

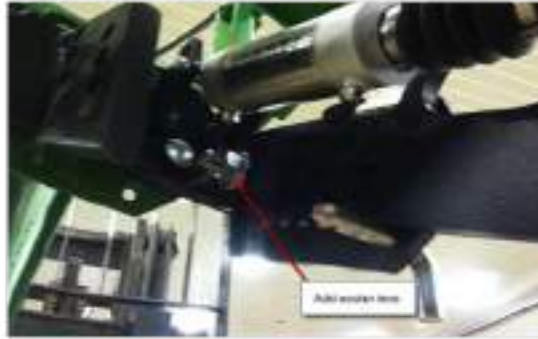

Step 2:

Secure the Cylinder Base Mounting Bracket to the face plate bracket using two - 1/2" X 1.5" carriage bolts and two - 1/2" Top Lock Hex Nuts.



Tighten to 75 lb-ft of torque.

The Base Mounting Bracket CAN be installed without disassembling the row cleaner frame and support plate. This is done by first inserting the upper carriage bolt into the row cleaner face plate bracket and then slipping the cylinder base bracket in behind the carriage bolt. Simultaneously, you will need to rotate the cylinder bracket so that it can slide in behind and wrap around the row cleaner support plate

Install the base of the Cylinder to this bracket using the Cylinder Base Pivot Pin (755149). Use the 5/8" OD X 7/16ID X 0.688"L Spacer Bushing (towards the interior of the row) and the 5/8" OD X 7/16ID X 0.829"L Spacer Bushing (towards the exterior of the row) to properly secure and align the cylinder in the Base Mount Bracket.

Note: When mounting on JD 7200/7300/17XX row units with LONG parallel arms (21 inches) the Air Cylinder must be: Installed using the bottom holes on the Rod Brackets Installed upside down (with fittings facing the ground).

Step 3:

Install the Cylinder Rod Mounting Bracket to the row cleaner frame using the supplied two - 1/2" X 1.25" GRD5 Bolts ZNY, and two - 1/2" GRD A ZN Top Lock Jam Nuts.



When installing the Cylinder Rod Mount Bracket, be sure it is properly aligned in the clevis yoke of the Rod. This may require the exact angle of the bracket to be tweaked or modified in order to more perfectly match the individual row unit.

Secure the Rod Mounting Bracket to the clevis yoke on the cylinder using the supplied cylinder rod pivot pin (755019) and cotter pin. Refer to the Mounting Hole Selection guide at the end of this section for more information on which mounting holes to use with this bracket.

When installing the Cylinder Rod Mount Bracket, the first priority is to ensure proper alignment in the clevis yoke of the Rod. There may be considerable slop or play between the clevis yoke and the rod mounting bracket. This is OK and will not negatively affect the performance of the system. This is intended to ease basic installation, especially on mildly deformed row cleaners. Pay close attention to the mounting location of this bracket. Consistent placement from row to row will provide consistent force from row to row and will prevent premature wear on the cylinder. The default pivot hole for the cylinder rod is the TOP HOLE of the bracket.

Note: The default pivot hole for the cylinder rod is the TOP HOLE in the bracket.

Verify the freedom of motion and clearance of components.

Ensure that the Row Cleaner does not 'hang' on the cylinder when extended. This may require extending the row cleaner until this situation is achieved, then selecting the pin location or stop bolt depth just above this depth.

Completed Cylinder Kit Installation



Maintenance Recommendations

If the bellows on the rubber boot become inverted or collapsed, locate the dimple on the rubber boot (near the Cylinder). Pinch the dimple open while articulating the Rod into and out of the Cylinder. This should allow the boot to re-seat properly.

Lubrication: Cylinders are manufactured with a non-migratory grease and should not require additional lubrication under normal operating conditions.

Mounting Hole Selection: 2967-007

Use this page to select the mounting location when using the Mounting Bracket — 755148

Top Hole:

- Installing the cylinder in the top holes will INCREASE the magnitude of the force applied to the row cleaner. Therefore;
 - To be used if MORE down force is desired when the system will generally be used in the down direction.
 - To be used if LESS down force is desired when the system will generally be used in the Lift direction.

Bottom Hole:

- Installing the cylinder in the bottom holes with DECREASE the magnitude of the force applied to the row cleaner. Therefor;
 - To be used if LESS down force is desired when the system will generally be used in the down direction.
 - To be used if MORE down force is desired when the system will generally be used in the lift direction.

Note: In general, all rows will be set to the same hole. However, some rows may require unique settings. A typical example would be a row unit directly behind a tractor tire. In this example, this row unit should be set to exert more force on the row cleaner than the surrounding rows. If the system is normally operated in LIFT mode, install this row unit in the bottom hole. If the system is normally operated in the DOWN mode, install this row unit in the top hole.



Caution: Risk of hyper-extending the row cleaner/cylinder kit beneath the row unit. DO NOT run the stop bolt too deep. The row cleaner should not be allowed to fall below 38 degrees below horizontal; this usually equates to NO LESS than 3/4" of thread showing on the stop bolt below the stop bolt bracket

755190 — Martin C-125: MTS, MTS-XP, or MTS-IH

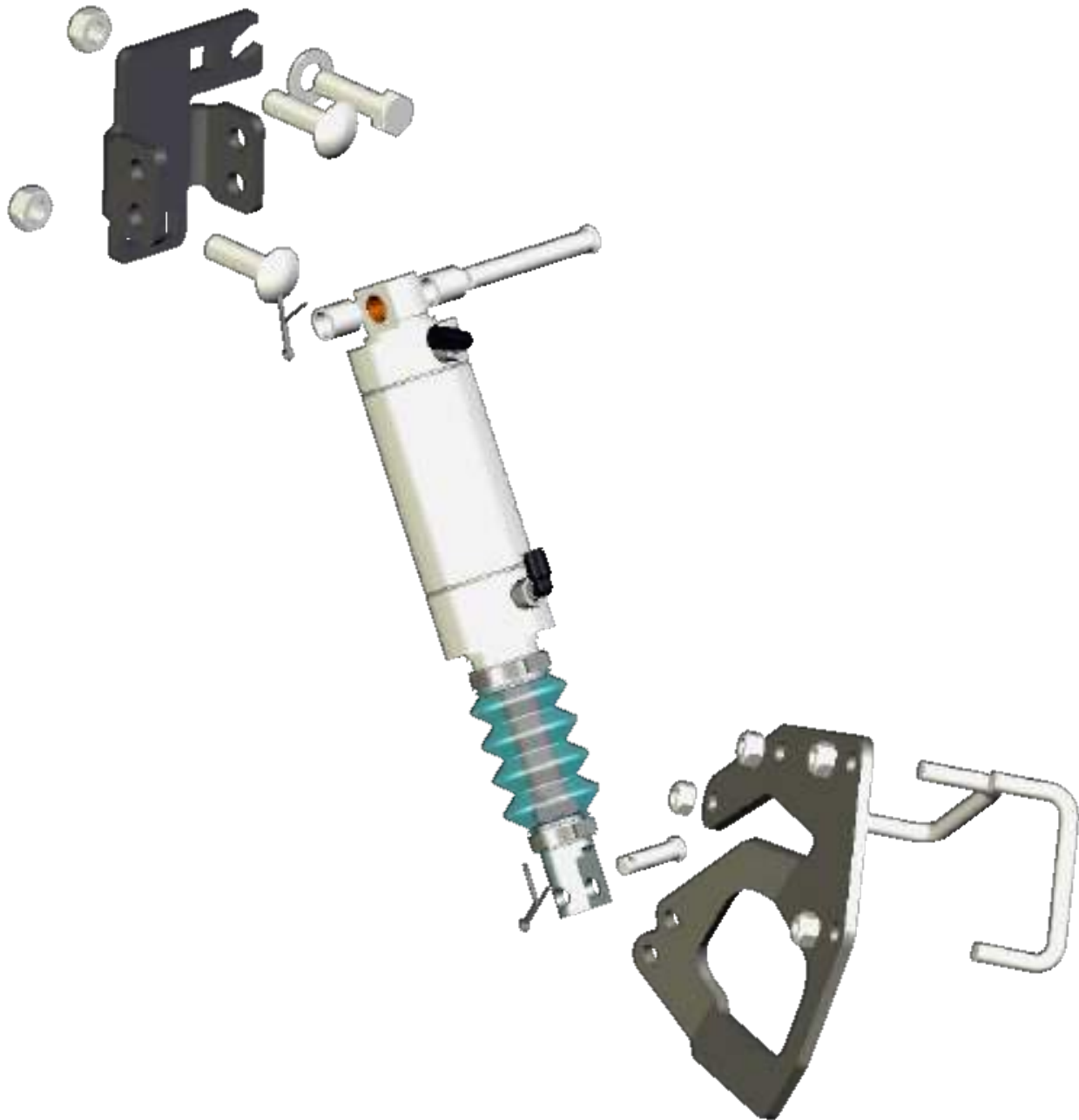

Notes and Compatibility Items

CASE IH

- Mount using bottom hole on the base bracket, top hole on the rod bracket, mount cylinder right side up, and set row cleaner stop bolt high enough so that fittings aren't crushed. Route airlines as shown in picture 1 at the end of this section.
- For 12x5 series planters, CleanSweep is not compatible with the Case IH lower parallel arm. If DeltaForce is installed, CleanSweep is compatible and follow the note above for all Case IH.

Kit Components

ITEM	QTY	PART NUMBER	PART NAME	DESCRIPTION
1	1	13210	Bolt	1/2"x1.75" GRD5 Bolt ZN
2	5	21823	Carriage Bolt	1/2"x1.25" GRD5 ZN Carriage
3	5	21825	Carriage Bolt	1/2"x1.25" GRD5 ZN Carriage
4	1	33086	Washer	1/2" SAE Flat ZN
5	4	37264	Hex Nut	3/8" Top Lock Hex Nut ZN
6	2	37268	Hex Nut	1/2" Top Lock Hex Nut ZN
7	2	37269	Top Lock Jam Nut	1/2" GRD A ZN
8	2	755007	U-Bolt	2.75" X 1/2" Plate
9	1	755008	Bracket	MTS cylinder Base Mount
10	1	755009	Bracket	MTS Cylinder Rod Mount
11	2	755017	Spacer	5/8" OD X 7/16 ID X 0.688 L
12	1	755018	Pin	Cylinder Base Pivot
13	1	755019	Pin	Cylinder Rod Pivot
14	1	755023	Air Cylinder	Complete Air Cylinder Assembly (Ordered Sep.)
15	2	755028	Cotter Pin	1/8" X 1"

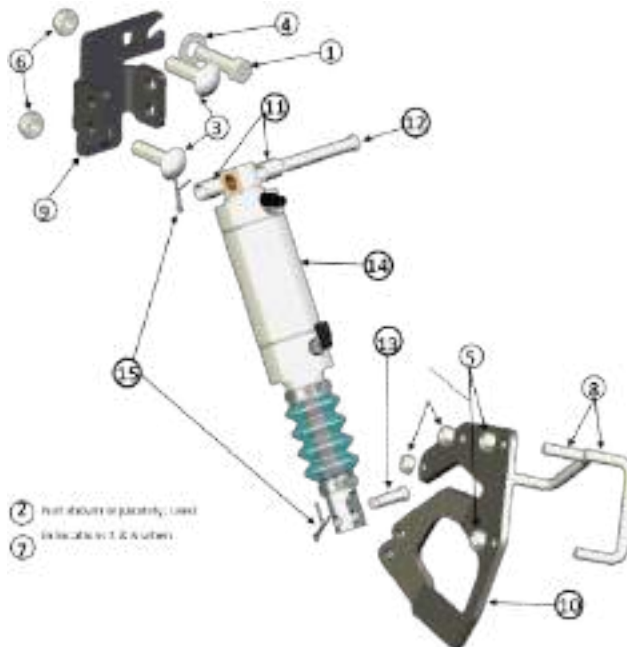

Installation

Step 1:

Secure the Cylinder Base Mounting Bracket to the face plate bracket.

JD 7200/7300/17XX Row Units:

- Mount using two — 1/2" X 1.75" carriage bolts and two — 1/2" top lock hex nuts.

JD 7000, Kinze, & White Row Units:

- Mount using one 1/2" X 1.75" carriage bolt, one 1/2" X 1.75" hex head bolt, one 1/2" SAE Flat Washer, and two 1/2" top lock hex nuts.

Case Row Units:

- Mount using two — 1/2" X 1.25" carriage bolts and two — 1/2" top lock jam nuts.

Tighten to 75 lb-ft of torque.

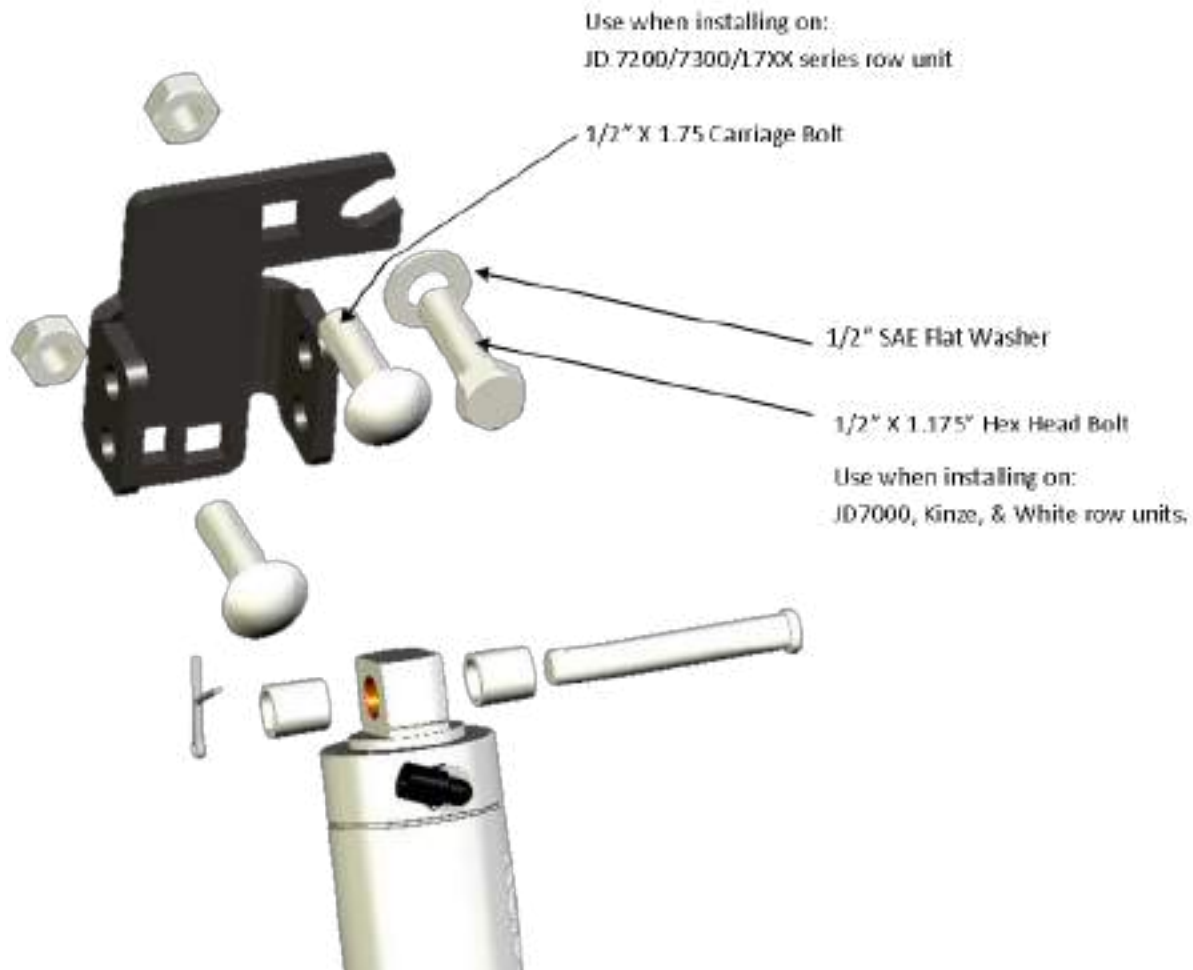

Install the base of the Cylinder to this bracket using the Cylinder Base Pivot Pin (755018). Use the 5/8" OD X 7/16ID X 0.688"L Spacer Bushing (towards the interior of the row) and the 5/8" OD X 7/16ID X 0.829"L Spacer Bushing (towards the exterior of the row) to properly secure and align the cylinder in the Base Mount Bracket.

Refer to the Mounting hole selection guide at the end of the 755190 instructions for more information on which mounting holes to use with this bracket. The default mounting location is the **TOP HOLE** in the

base mount and the **TOP HOLE** in the rod mount. Note: When mounting this bracket on Case IH row unit, mount using bottom hole on base bracket, top hole on rod bracket, cylinder right side up, and set row cleaner stop bolt high enough so that the fittings aren't crushed.

When installing the Cylinder Rod Mount Bracket, the first priority is to ensure proper alignment in the clevis yoke of the Rod. There may be considerable slop or play between the clevis yoke and the rod mounting bracket. This is OK and will not negatively affect the performance of the system. This is inherent in the U-Bolt fastener design and is intended to ease basic installation, especially on mildly deformed row cleaners. Pay close attention to the mounting location of this bracket. Consistent placement from row to row will provide consistent force from row to row and will prevent premature wear on the cylinder.

Step 2:

Install the Cylinder Rod Mounting Bracket to the row cleaner frame using the supplied 2.75" X 1/2" U-bolts (755007) and four - 3/8" Top Lock Hex Nuts (37264). Do not tighten until the cylinder has been properly aligned.

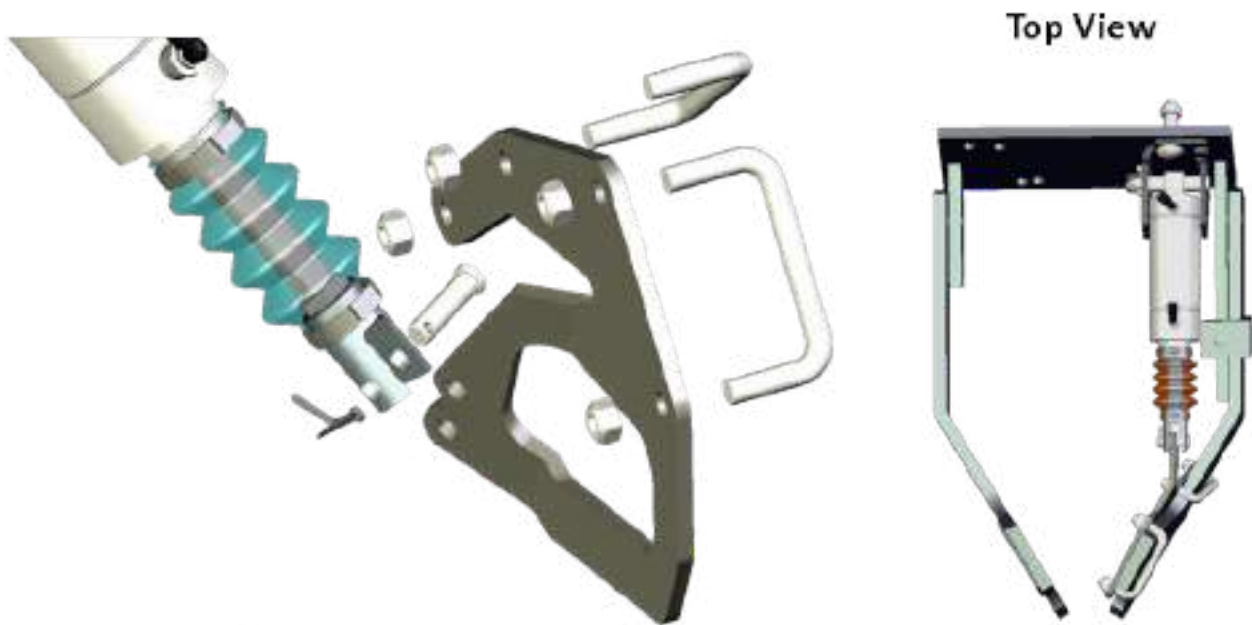

Secure the Rod Mounting Bracket to the clevis yoke on the cylinder using the supplied cylinder rod pivot pin (755019) and cotter pin.

Once the Rod Mounting Bracket has been properly aligned, secure the bracket by tightening the U- bolts to 30 lb-ft of torque.

Verify the freedom of motion and clearance of components.

Ensure that the Row Cleaner does not 'hang' on the cylinder when extended. This may require extending the row cleaner until this situation is achieved, then selecting the pin location or stop bolt depth just above this depth.

Completed Cylinder Kit Installation



Maintenance Recommendations

If the bellows on the rubber boot become inverted or collapsed, locate the dimple on the rubber boot (near the Cylinder). Pinch the dimple open while articulating the Rod into and out of the Cylinder. This should allow the boot to re-seat properly.

Lubrication: Cylinders are manufactured with a non-migratory grease and should not require additional lubrication under normal operating conditions.

Mounting Hole Selection

Use this page to select the mounting location when using the MTS Mounting Bracket — 755008

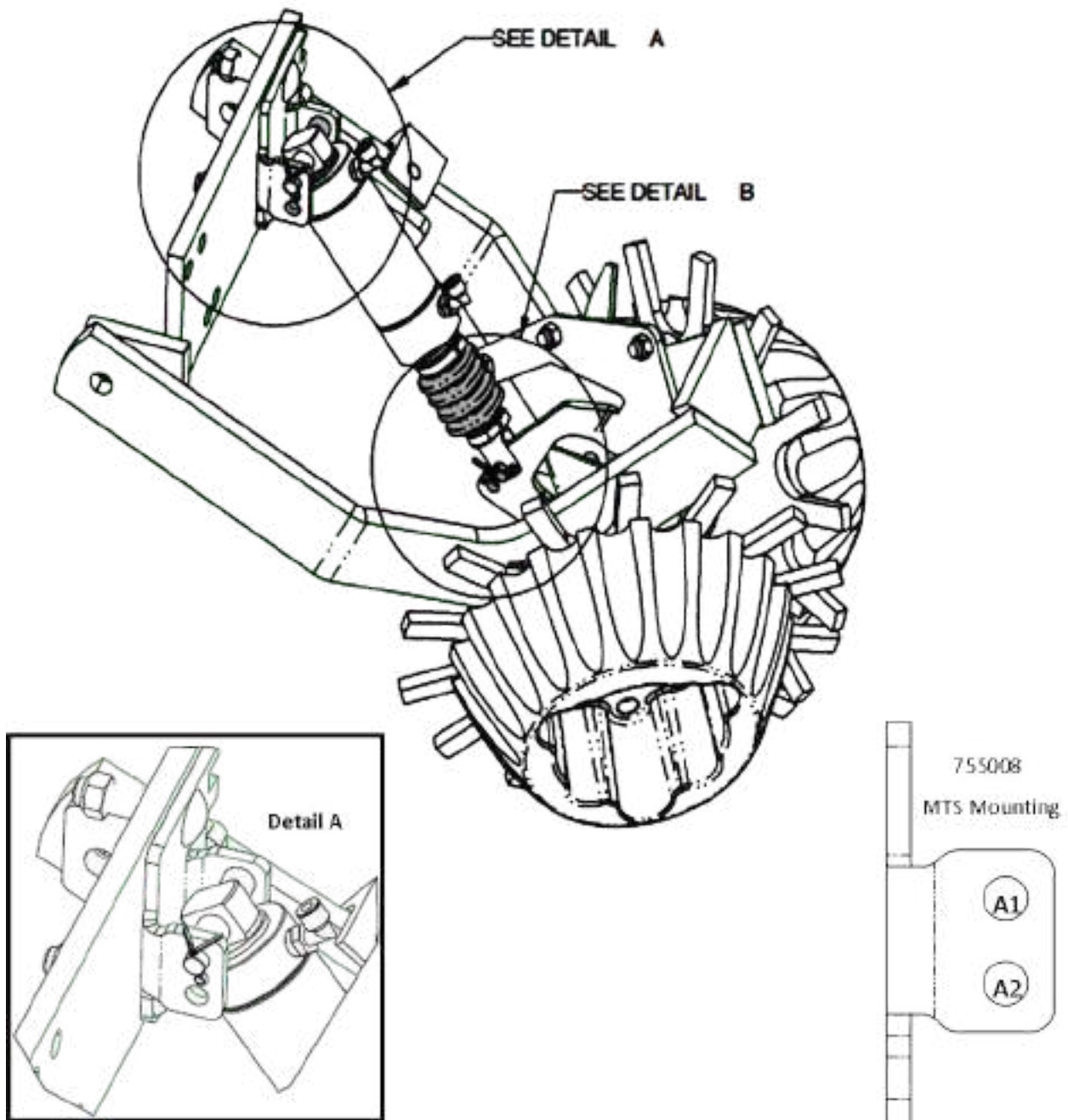

Hole A1 (Top Hole):

- Installing the cylinder in the top holes will INCREASE the magnitude of the force applied to the row cleaner. Therefore;
 - To be used if MORE down force is desired when the system will generally be used in the down direction.
 - To be used if LESS down force is desired when the system will generally be used in the Lift direction.

Hole A2 (Bottom Hole):

- Installing the cylinder in the bottom holes will DECREASE the magnitude of the force applied to the row cleaner. Therefore;

- To be used if LESS down force is desired when the system will generally be used in the down direction.
- To be used if MORE down force is desired when the system will generally be used in the Lift direction.

Note: The hole used on the Rod Mount Bracket should correspond to the same hole used on the Base Mount Bracket. e.g. Top to Top and Bottom to Bottom.

Note: In general, all rows will be set to the same hole. However, some rows may require unique settings. A typical example would be a row unit directly behind a tractor tire. In this example, this row unit should be set to exert more force on the row cleaner than the surrounding rows. If the system is normally operated in LIFT mode, install this row unit in the bottom hole. If the system is normally operated in the DOWN mode, install this row unit in the top hole.



Caution: Risk of hyper-extending the row cleaner/cylinder kit beneath the row unit. DO NOT run the stop bolt too deep. The row cleaner should not be allowed to fall below 38 degrees below horizontal; this usually equates to NO LESS than 3/4" of thread showing on the stop bolt below the stop bolt bracket

Note: For all Case IH installations, route airlines as shown.



755195 — Martin C-125: MTR, MTR-XP, or MTR-IH



Notes and Compatibility Items

JD 7200/7300/17XX

- With regular parallel arms (14") and chain drive: If JD cast coulter is installed, optional shim (755159) may be necessary to help align the cylinder brackets.
- With regular parallel arms (14") and pro drive: JD Mount using bottom holes the rode and base brackets, flip cylinder upside down. If JD cast coulter is installed, optional shim (755159) may be necessary to help align the cylinder brackets.
- With long parallel arms (21") and JD Cast Coulter, UMO100, Yetter, or Dawn Single Arm Coulter: Mount bottom holes on both rod and base brackets, flip cylinder upside down, and install 1/4" stop blocks (726530). Shim (755159) installed under the cylinder base bracket may be necessary to help align the cylinder brackets with the JD Cast Coulter.
- With long parallel arms (21") and no Coulter: Mount using bottom holes on both rod and base brackets, flip cylinder upside down, and install 1/8" stop blocks (755202).

Kinze

- Kinze coulter bracket must be significantly modified in order to make the base bracket fit. (See Knowledge Base article #49 for details)

Kit Components

ITEM	QTY	PART NUMBER	PART NAME	DESCRIPTION
1	2	21826	Carriage Bolt	1/2" x 2" GRD5 ZN Round Head Bolt
2	4	37264	Hex Nut	3/8" Top Lock Hex Nut ZN
3	2	37268	Hex Nut	1/2" Top Lock Hex Nut ZN
4	1	755004	Bracket	MTR Cylinder Base Mount
5	1	755006	Bracket	MTR Cylinder Rod Mount
6	2	755007	U-Bolt	2.75" X 1/2" Plate
7	2	755017	Spacer	5/8" OD X 7/16 ID X 0.688"L
8	1	755018	Pin	Cylinder Base Pivot
9	1	755019	Pin	Cylinder Rod Pivot
10	1	755023	Air Cylinder	Complete Air Cylinder Assembly (Sold Sep)
11	2	755028	Cotter Pin	1/8" x 1"

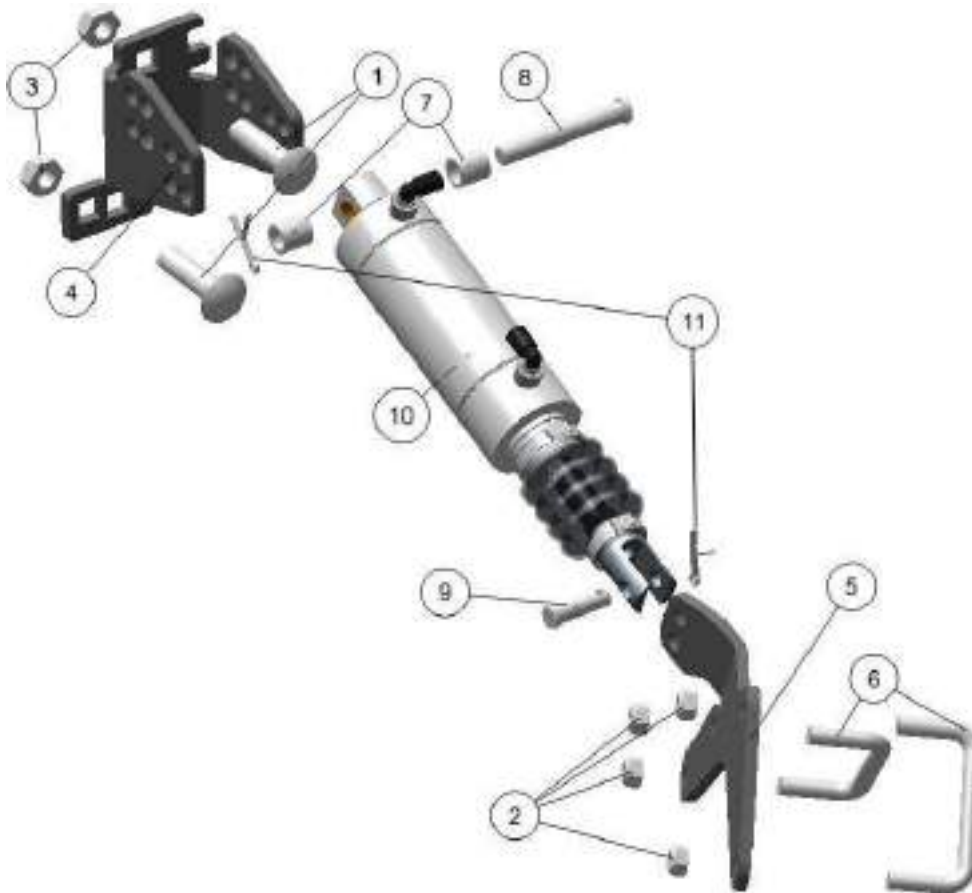

Installation

Step 1:

Secure the Cylinder Base Mounting Bracket to the face plate bracket using two — 1/2" X 1.75" carriage bolts and two — 1/2" Top Lock Hex Nuts.



Tighten to 75 lb-ft of torque.

Install the base of the Cylinder to this bracket using the Cylinder Base Pivot Pin (755018). Use the 5/8" OD X 7/16ID X 0.688"L Spacer Bushing (towards the interior of the row) and the 5/8" OD X 7/16ID X 0.829"L Spacer Bushing (towards the exterior of the row) to properly secure and align the cylinder in the Base Mount Bracket.

Refer to the Mounting Hole Selection guide at the end of this section for more information on which mounting holes to use with this bracket.

Step 2:

Install the Cylinder Rod Mounting Bracket to the row cleaner frame using the supplied 2.75" X 1/2" U-bolts (755007) and four - 3/8" Top Lock Hex Nuts (37264). Do not tighten until the cylinder has been properly aligned.

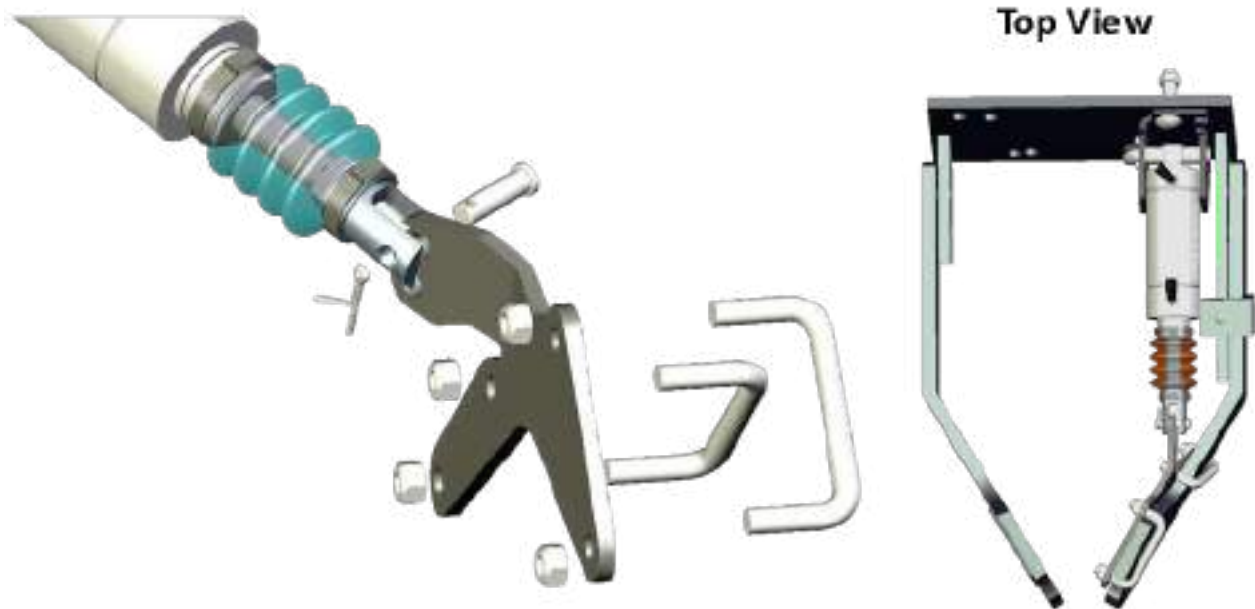

When installing the Cylinder Rod Mount Bracket, the first priority is to ensure proper alignment in the clevis yoke of the Rod. There may be considerable slop or play between the clevis yoke and the rod mounting bracket. This is OK and will not negatively affect the performance of the system. This is inherent in the U- Bolt fastener design and is intended to ease basic installation, especially on mildly deformed row cleaners. Pay close attention to the mounting location of this bracket. Consistent placement from row to row will provide consistent force from row to row and will prevent premature wear on the cylinder.

Secure the Rod Mounting Bracket to the clevis yoke on the cylinder using the supplied cylinder rod pivot pin (755019) and cotter pin. Refer to the Mounting Hole Selection guide at the end of this section for more information on which mounting holes to use with this bracket.

Ensure that the Row Cleaner does not 'hang' on the cylinder when extended. This may require extending the row cleaner until this situation is achieved, then selecting the pin location or stop bolt depth just above this depth.

Once the Rod Mounting Bracket has been properly aligned, secure the bracket by tightening the U- bolts to 30 lb-ft of torque.

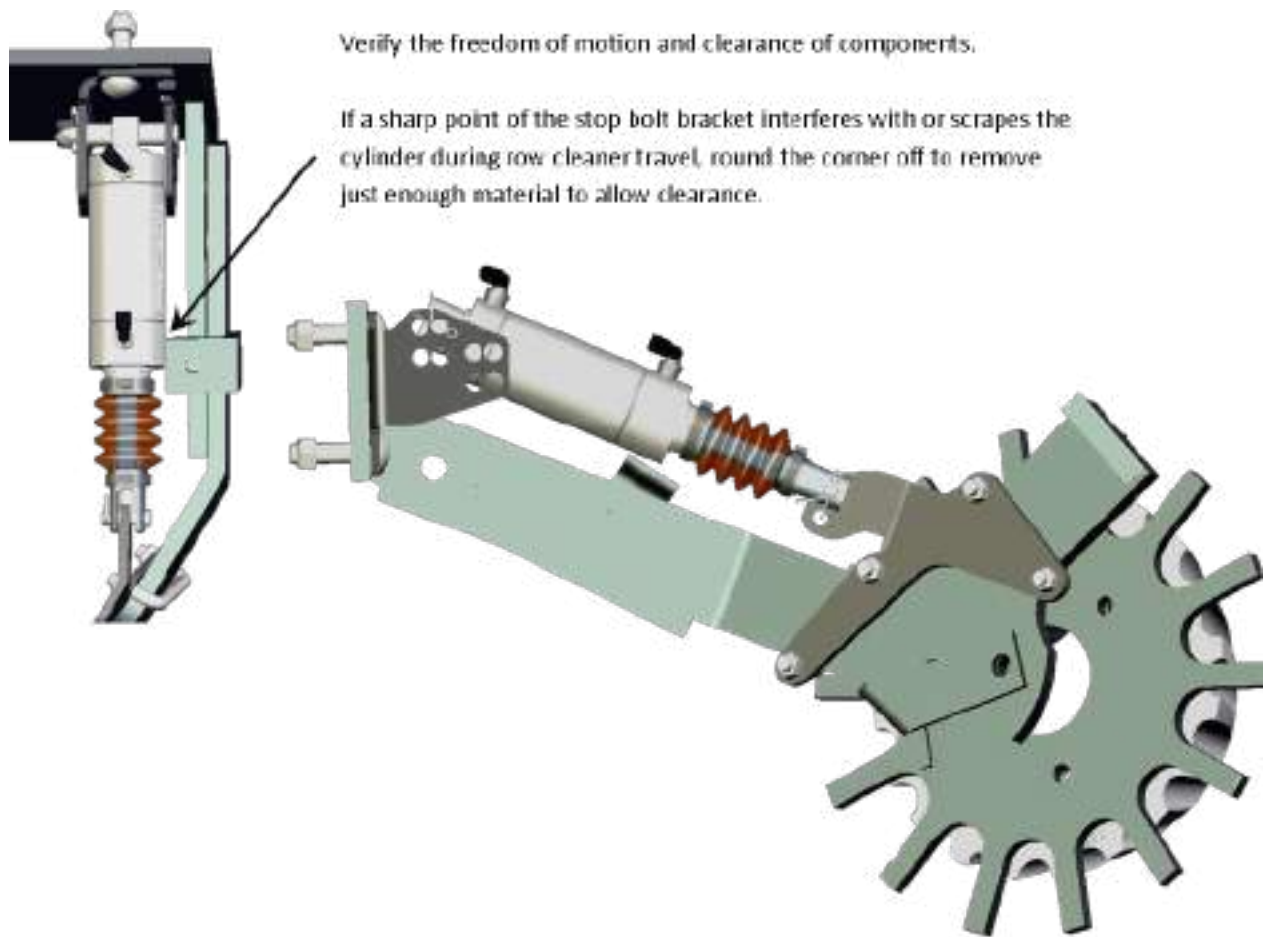

Maintenance Recommendations

If the bellows on the rubber boot become inverted or collapsed, locate the dimple on the rubber boot (near the Cylinder). Pinch the dimple open while articulating the Rod into and out of the Cylinder. This should allow the boot to re-seat properly.

Lubrication: Cylinders are manufactured with a non-migratory grease and should not require additional lubrication under normal operating conditions.

Mounting Hole Selection

Use this page to select the mounting location when using the MTS Mounting Bracket — 755008

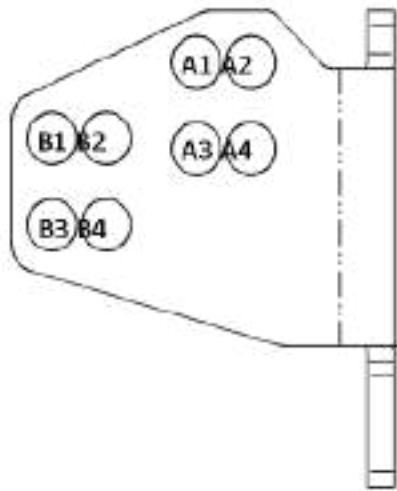

755004
Cylinder Base
Mounting Bracket

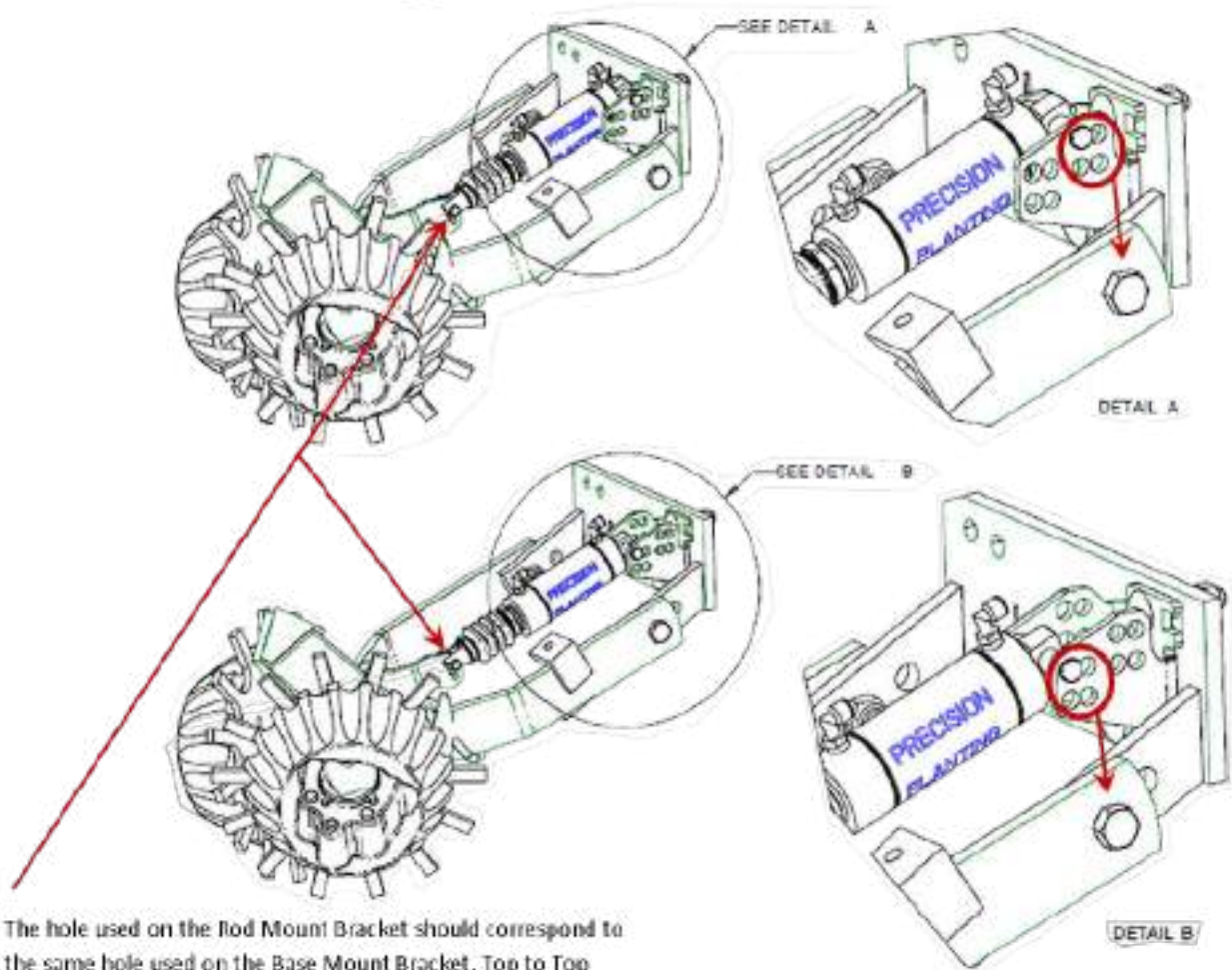

The hole used on the Rod Mount Bracket should correspond to the same hole used on the Base Mount Bracket. Top to Top
Bottom to Bottom

A Range Holes:

- To be used with Yetter Titan 2967-035 and Martin MTR when the row cleaner frame pivots in the rear holes (Detail A)

B Range Holes:

- To be used with Martin MTR when the row cleaner frame pivots in the front holes (Detail B)

Hole 1 and 2 (Top Holes, both Ranges):

- Installing the cylinder in the top holes will INCREASE the magnitude of the force applied to the row cleaner. Therefore;
 - To be used if MORE down force is desired when the system will generally be used in the down direction.
 - To be used if LESS down force is desired when the system will generally be used in the Lift direction.

Note Not to be used with Long Parallel Arms or JD 7000 row units.

Holes 3 and 4 (Bottom Holes, both Ranges):

- Installing the cylinder in the bottom holes will DECREASE the magnitude of the force applied to the row cleaner. Therefore;
 - To be used if LESS down force is desired when the system will generally be used in the down direction.
 - To be used in MORE down force is desired when the system will generally be used in the Lift direction.

Holes 1 and 3 (Front Holes, both Ranges):

- To be used if bracket is mounted directly to the row cleaner face plate bracket.

Holes 2 and 4 (Rear Holes, both Ranges):

- To be used if bracket is mounted on top of another attachment. (Row unit mounted coulter, UMO100, etc.)

Note: In general, all rows will be set to the same hole. However, some rows may require unique settings. A typical example would be a row unit directly behind a tractor tire. In this example, this row unit should be set to exert more force on the row cleaner than the surrounding rows. If the system is normally operated in LIFT mode, install this row unit in the bottom hole. If the system is normally operated in the DOWN mode, install this row unit in the top hole.



Caution: Risk of hyper-extending the row cleaner/cylinder kit beneath the row unit. DO NOT run the stop bolt too deep. The row cleaner should not be allowed to fall below 38 degrees below horizontal; this usually equates to NO LESS than 3/4" of thread showing on the stop bolt below the stop bolt bracket

Installation Notes

Row Unit: JD 7200 with Reg. or Long Parallel Arms w/ JD Coulter

If a JD Cast Iron Coulter frame is installed, the draft angle of the cast iron bracket may lead to the misalignment of the two cylinder mounting brackets. If the misalignment is so severe that the cylinder cannot be installed freely, install the 755159 shim directly behind the cylinder base mounting bracket.

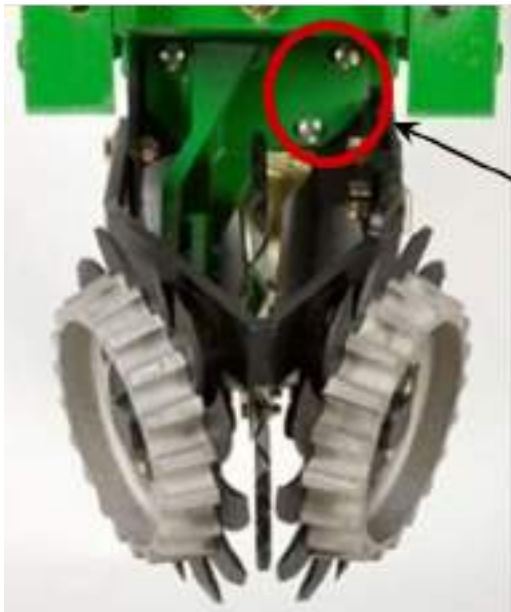

755159 Shim



755200 — Martin BD1360

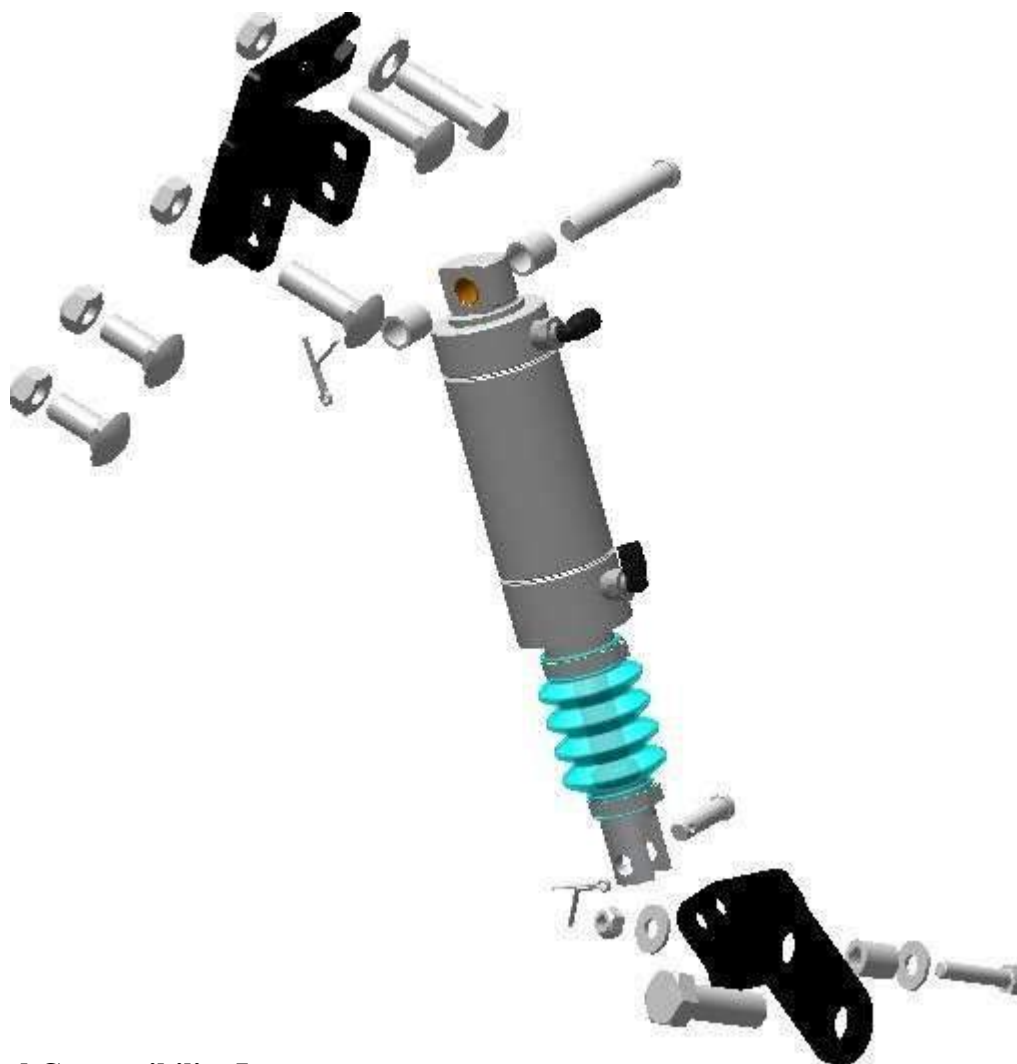

Notes and Compatibility Items

JD 7200/7300/17XX

-

- With long parallel arms (21"): If AirForce bracket 726551 is installed, use bottom holes on both rod and base brackets. Flip cylinder upside down.

Case IH

- Mount using bottom hole on the base bracket, top hole on the rod bracket, cylinder right side up, and set row cleaner stop bolt high enough so that fittings aren't crushed. Route airlines shown in picture 1 at the end of this section.
- CleanSweep is not compatible with 12X5 series planters unless DeltaForce is installed. With DeltaForce installed, mount using bottom hole on the base bracket, top hole on the rod bracket, cylinder right side up, and set the row cleaner stop bolt high enough so that fittings are not crushed. Route the airlines as shown in picture 1 at the end of this section.

Kit Components

ITEM	QTY	PART NUMBER	PART NAME	DESCRIPTION
1	1	13210	Bolt	1/2" x 1.75" GRD5 Bolt ZN
2	2	21823	Bolt, Round Head	1/2" X 1-1/4" GRD5 ZN Carriage Bolt
3	2	21825	Bolt, Round Head	1/2" X 1-3/4" GRD5 ZN Carriage Bolt
4	1	24117	Bolt	5/16"-18 X 1.5" GRD 5 BOLT ZN
5	1	33086	Washer	1/2" SAE Flat Washer ZN
6	2	37268	Hex Nut	1/2" Top Lock Nut ZN
7	2	37269	Top Lock Jam Nut	1/2" GRD A ZN
8	1	37262	Hex Nut	5/16-18 Top Lock Nut ZN
9	1	755008	Bracket	MTS Cylinder Base Mount
10	2	755017	Spacer	5/8" OD X 7/16" ID X 0.688L
11	1	755018	Pin	Cylinder Base Pivot
12	1	755019	Pin	Cylinder Rod Pivot
13	1	755023	Air Cylinder	Complete Assembly (Sold Sep)
14	2	755028	Cotter Pin	1/8" X 1"
15	1	755158	Bracket	BD 1360 Rod Mount
16	1	13310G	Bolt	5/8" X 1-3/4" GRD5 Bolt ZN w/Nylon
17	1	755194	Bushing	5/16" ID X 5/8" OD X .750"
18	1	33006	Washer	5/16" USS Flat ZN

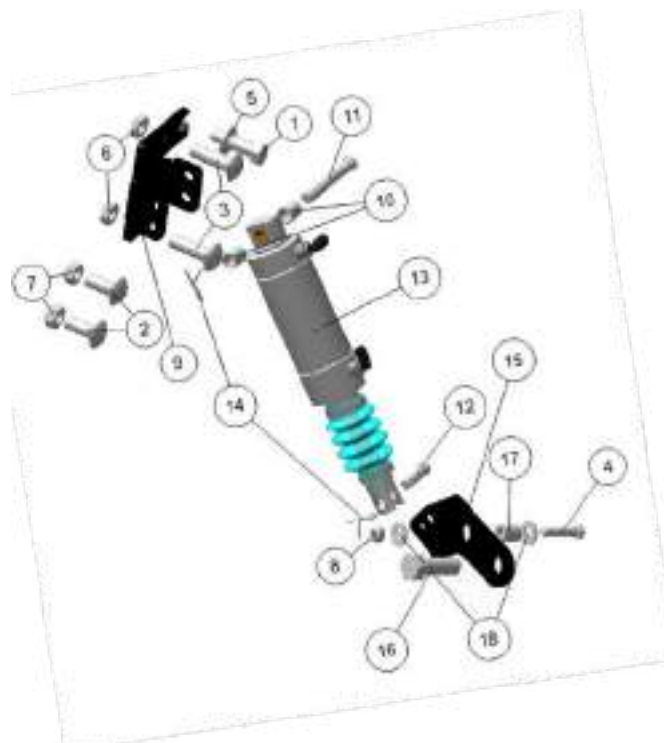

Installation

Note: This kit fits Martin row cleaner model WA1360, which mounts directly to the row unit face plate (NO COULTER).

Step 1:

Secure the Cylinder Base Mounting Bracket to the face plate bracket using two — 1/2" X 1.75" carriage bolts and two — 1/2" Top Lock Hex Nuts.

JD 7200/7300/17XX Row Units:

- Mount using two — 1/2" X 1.75" carriage bolts and two — 1/2" top lock nuts.

JD 7000, Kinze, & White Row Units:

- Mount using one 1/2" X 1.75" carriage bolt, one 1/2" X 1.75" hex head bolt, one 1/2" SAE Flat Washer, and two 1/2" top lock hex nuts.

Case Row Units:

- Mount using two - 1/2" X 1.25" carriage bolts and two - 1/2" Top Lock Jam Nuts GRD A ZN This will allow clearance for gauge wheel rocker arms.
- **This Installation requires** the use of the bottom hole on the base bracket, the top hole on the rod bracket, cylinder right side up (fittings facing the sky), and setting the row cleaner stop bolt high enough to prevent crushing the fittings.

Tighten to 75 lb-ft of torque.

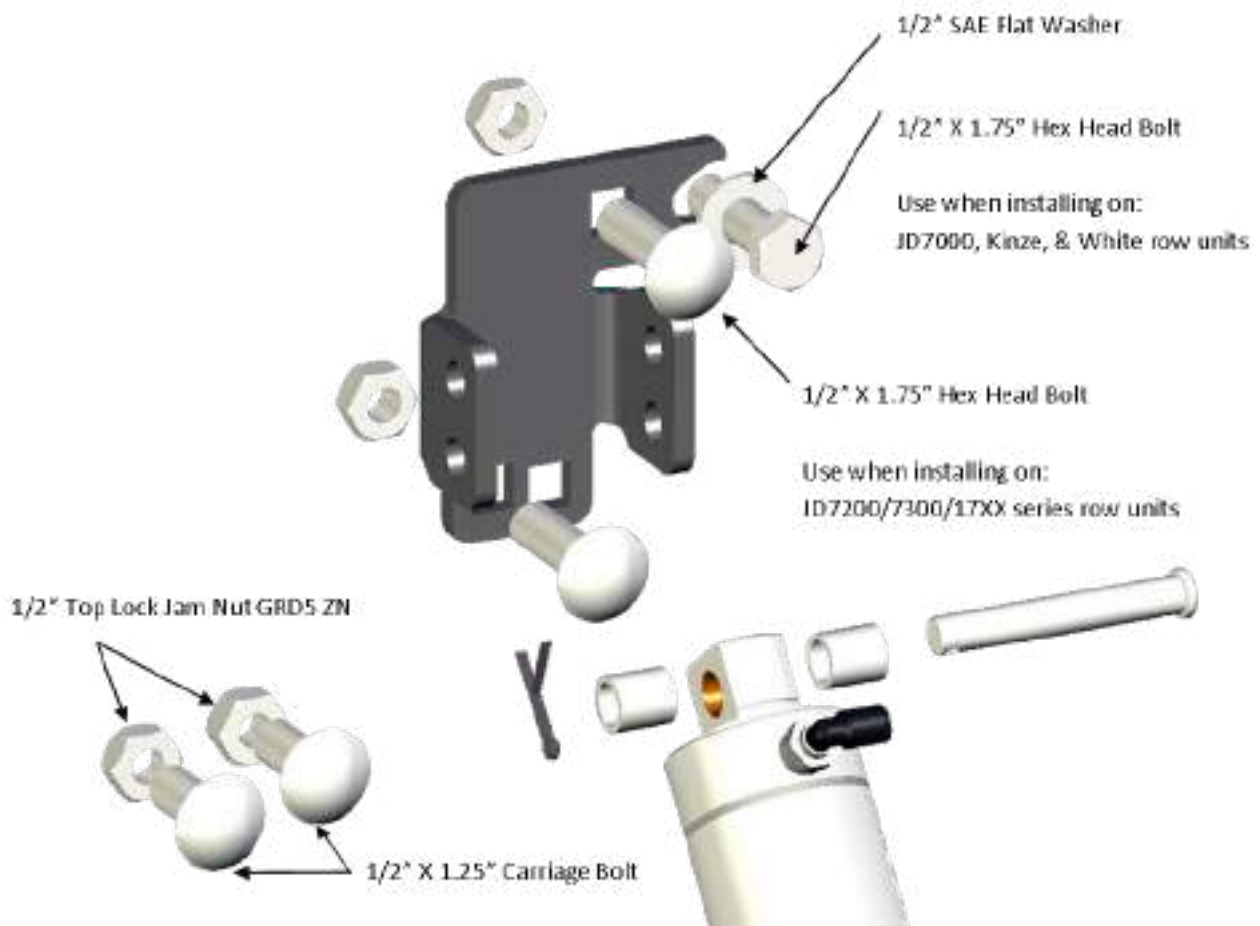

Install the base of the Cylinder to this bracket using the Cylinder Base Pivot Pin (755018). Use the two -5/8" OD X 7/16ID X 0.688"L Spacer Bushings to properly secure and align the cylinder in the Base Mount Bracket.

Refer to the Mounting Hole Selection guide at the end of this section for more information on which mounting holes to use with this bracket.

Step 2:

Install the Cylinder Rod Mounting Bracket to the row cleaner frame using the supplied 5/8" X 1-3/4" GRD5 Bolt ZN w/Nylon (13310G), 5/16-18 x 1.5 GRD 5 BOLT, two 5/16" washers, 5/16" ID x 5/8" OD bushing, and 5/16-18 TOP LOCK NUT.

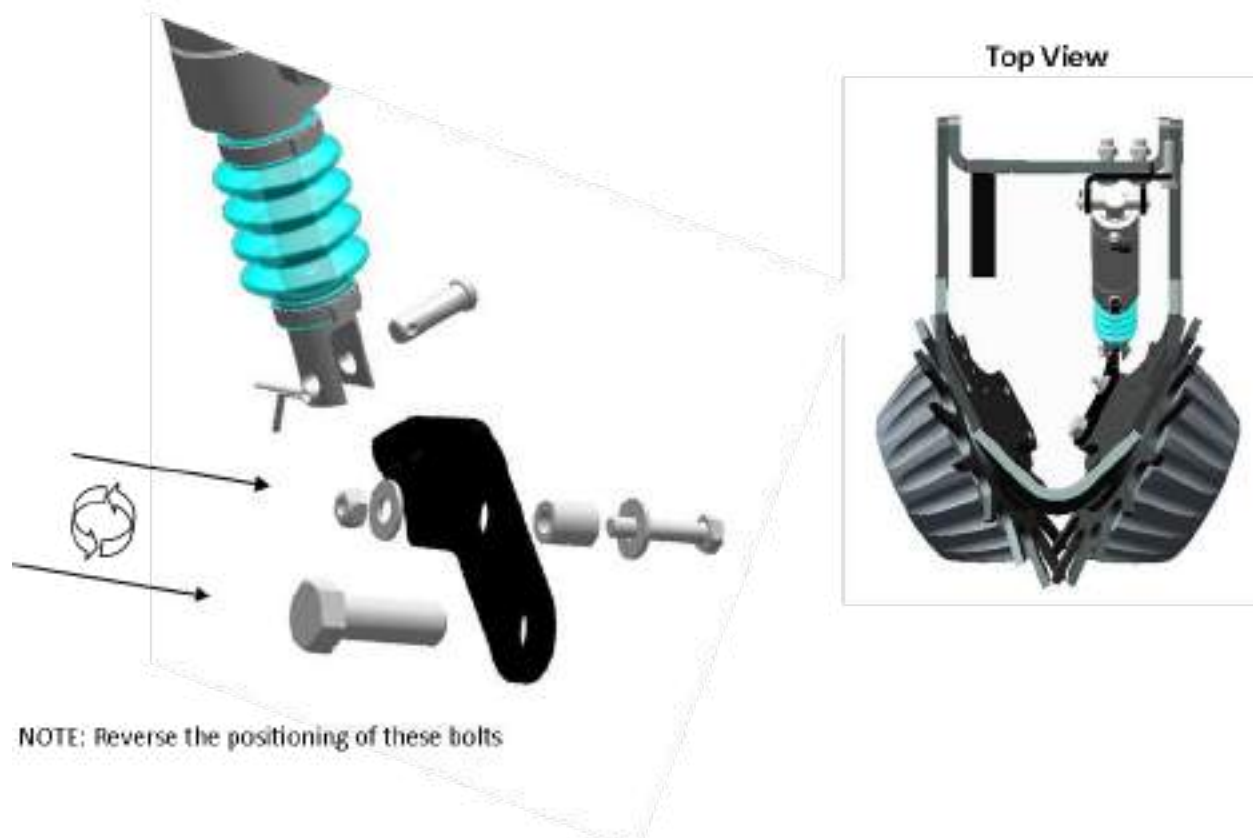

This will require removal of the existing 5/8" Bolt installed through the hub. When re-installing, re-use the existing 5/8" washer, ensure proper alignment of all components, and that the hub is firmly secured.

When installing the Cylinder Rod Mount Bracket, the first priority is to ensure proper alignment in the clevis yoke of the Rod. There may be considerable slop or play between the clevis yoke and the rod mounting bracket. This is OK and will not negatively affect the performance of the system. This is inherent in the U- Bolt fastener design and is intended to ease basic installation, especially on mildly deformed row cleaners. Pay close attention to the mounting location of this bracket. Consistent placement from row to row will provide consistent force from row to row and will prevent premature wear on the cylinder.

Secure the Rod Mounting Bracket to the clevis yoke on the cylinder using the supplied cylinder rod pivot pin (755019) and cotter pin. Refer to the Mounting Hole Selection guide at the end of this section for more information on which mounting holes to use with this bracket.

Ensure that the Row Cleaner does not 'hang' on the cylinder when extended. This may require extending the row cleaner until this situation is achieved, then selecting the pin location or stop bolt depth just above this depth.

Once the Rod Mounting Bracket has been properly aligned, secure the bracket by tightening the U- bolts to 30 lb-ft of torque.

Completed Cylinder Kit Installation

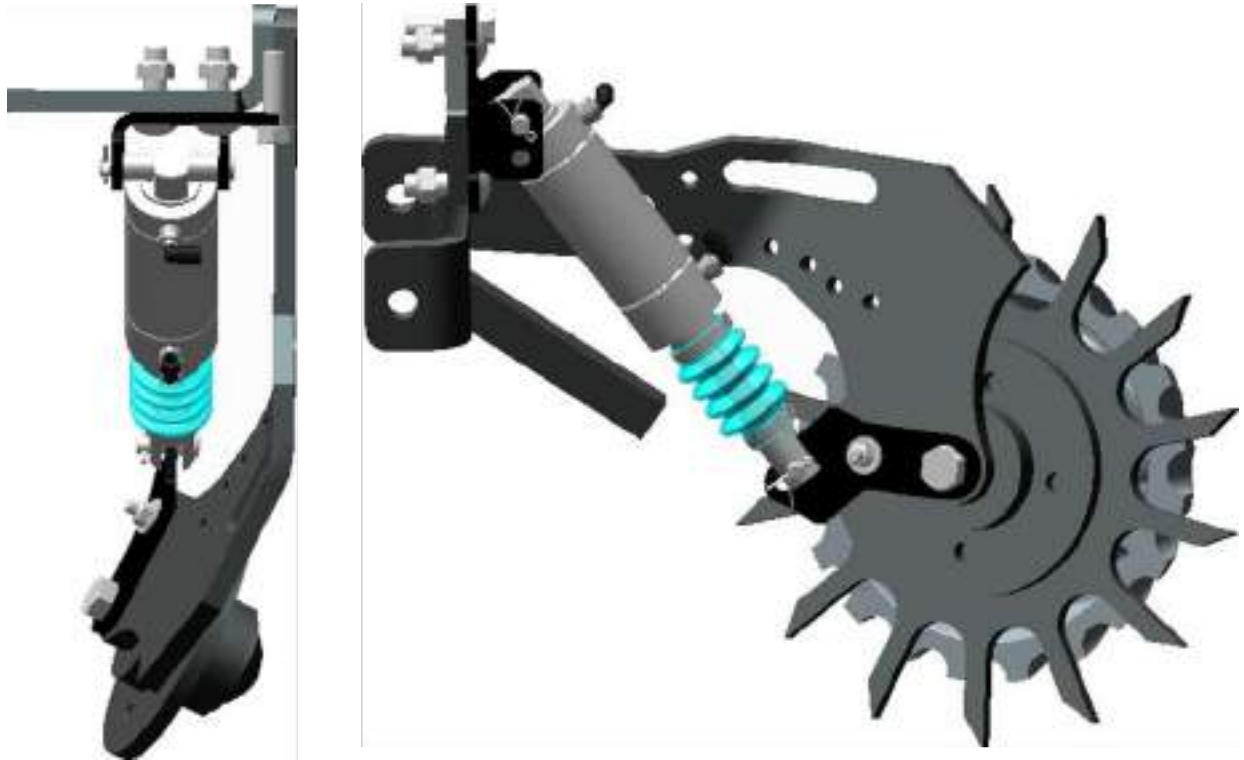

Maintenance Recommendations

If the bellows on the rubber boot become inverted or collapsed, locate the dimple on the rubber boot (near the Cylinder). Pinch the dimple open while articulating the Rod into and out of the Cylinder. This should allow the boot to re-seat properly.

Lubrication: Cylinders are manufactured with a non-migratory grease and should not require additional lubrication under normal operating conditions.

Mounting Hole Selection

Use this page to select the mounting location when using the Mounting Bracket — 755008

Note: If AirForce bracket 726551 is installed, use the bottom holes on both rod and base brackets. The default mounting location is the TOP HOLE in the base mount and the TOP HOLE in the rod mount.

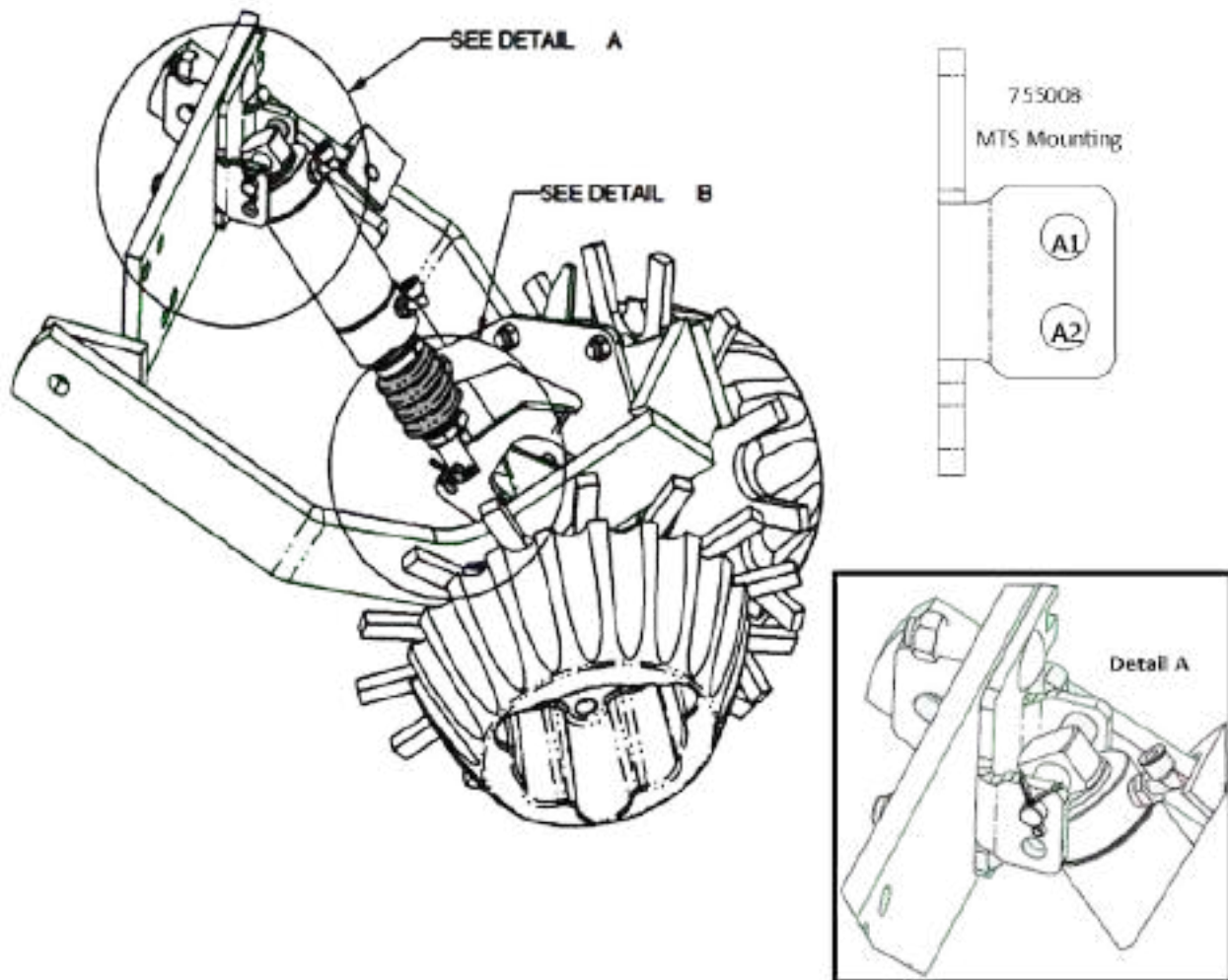

Hole A1 (Top Hole):

- Installing the cylinder in the top holes will INCREASE the magnitude of the force applies to the row cleaner. Therefore;
 - To be used if MORE down force is desired when the system will generally be used in the down direction.
 - To be used if LESS down force is desired when the system will generally be used in the lift direction.

Hole A2 (Bottom Hole):

- Installing the cylinder in the bottom holes will DECREASE the magnitude of the force applied to the row cleaner. Therefore;
 - To be used if LESS down force is desired when the system will generally be used in the down direction.
 - To be used in MORE down force is desired when the system will generally be used in the Lift direction.

The hole used on the Rod Mount Bracket should correspond to the same hole used on the Base Mount Bracket. Top to Top, Bottom to Bottom.

Note: In general, all rows will be set to the same hole. However, some rows may require unique settings. A typical example would be a row unit directly behind a tractor tire. In this example, this row unit should be set to exert more force on the row cleaner than the surrounding rows. If the system is normally operated in LIFT mode, install this row unit in the bottom hole. If the system is normally operated in the DOWN mode, install this row unit in the top hole.



Caution: Risk of hyper-extending the row cleaner/cylinder kit beneath the row unit. DO NOT run the stop bolt too deep. The row cleaner should not be allowed to fall below 38 degrees below horizontal; this usually equates to NO LESS than 3/4" of thread showing on the stop bolt below the stop bolt bracket

For all Case IH installations, route airlines as shown.



755205 — Martin BDC 1360

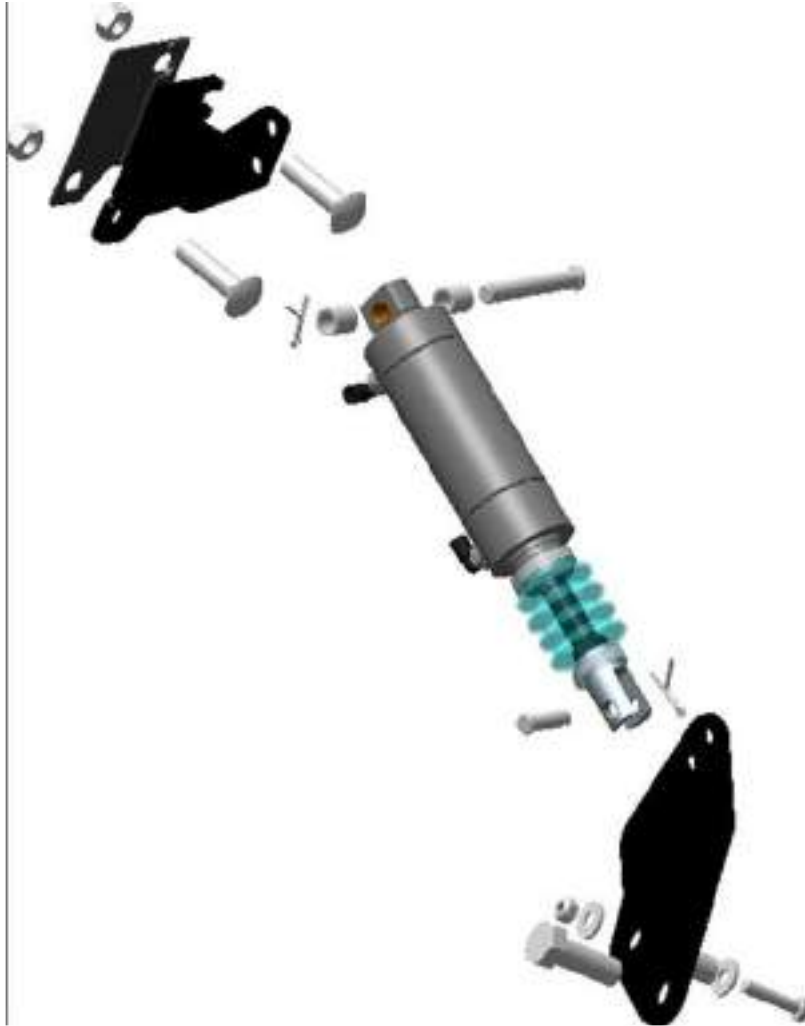

Notes and Compatibility Items

JD 7200/7300/17XX

- With long parallel arms (21") and JD Case Coulter: Mount using bottom holes on both rod and base brackets, flip cylinder upside down, and install 1/4" stop kit (726530). Confirm clearance around the cylinder through full range of motion before use.

White 9000

- Mount using bottom hole on both rod and base brackets. Flip cylinder upside down.

Kit Components

ITEM	QTY	PART NUMBER	PART NAME	DESCRIPTION
1	2	21826	Bolt, Round Head	1/2" x 2" GRD5 Carriage
2	1	13059	Bolt	5/16"-18 X 1.5 GRD5 Bolt ZN
3	2	37268	Hex Nut	1/2" Top Lock Nut ZN
4	1	37262	Hex Nut	5/16"-18 Top Lock Nut ZN
5	2	755017	Spacer	5/8" OD X 7/16" ID X .688"L
6	1	755018	Pin	Cylinder Base Pivot
7	1	755019	Pin	Cylinder Rod Pivot
8	2	755028	Cotter Pin	1/8" X 1"
9	1	755157	Bracket	BDC 1360 Base Mount
10	1	755167	Bracket	BDC 1360 Rod Mount
11	1	755174	Shim	Cylinder Base Mount on 755205
12	1	13310G	Bolt	5/8" X 1.75" GRD5 BLT ZN w/Thread Lock
13	2	33006	Washer	5/16" USS Flat ZN
14	1	755194	Bushing	5/16" ID x 5/8" OD x .750"
15	1	755023	Cylinder	Complete Assembly (Sold Sep.)

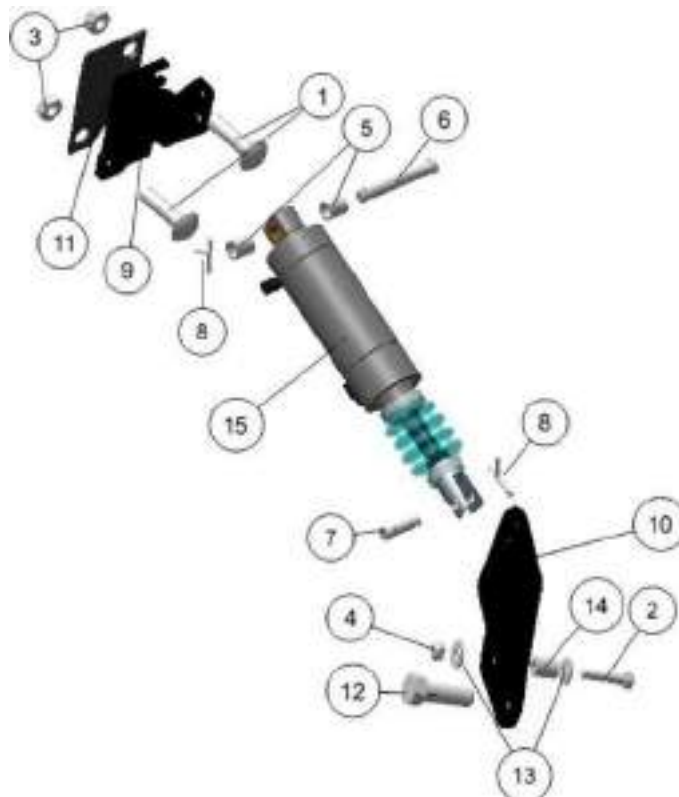

Installation

Note: Images in these instructions depict installation on a JD row unit with Long Parallel arms with a JD Case Coultter. For installation on JD row units with REGULAR parallel arms, the cylinder can be installed right side up with the fittings facing up.

Step 1:

Secure the Cylinder Base Mounting Bracket to the face plate bracket using two — 1/2" X 1.75" carriage bolts and two — 1/2" Top Lock Hex Nuts. Install the Shim — 755174 as shown.

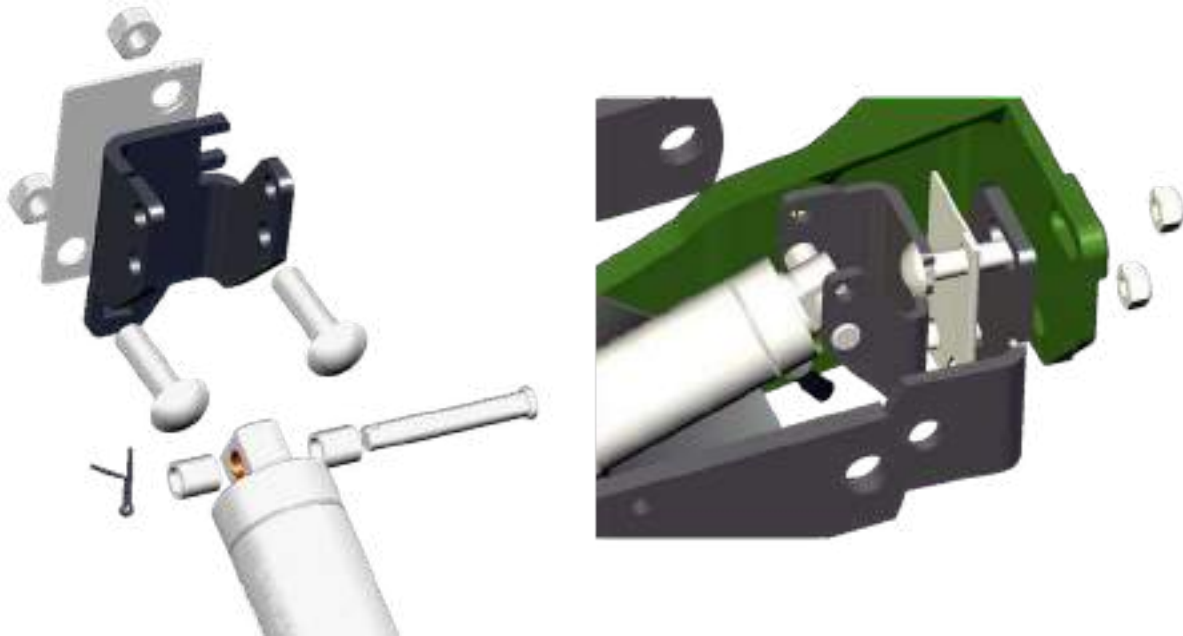

Tighten to 75 lb-ft of torque.

Install the base of the Cylinder to this bracket using the Cylinder Base Pivot Pin (755018). Use the two -5/8" OD X 7/16ID X 0.688"L Spacer Bushings to properly secure and align the cylinder in the Base Mount Bracket.

Refer to the Mounting Hole Selection guide at the end of this section for more information on which mounting holes to use with this bracket.

Step 2:

Install the Cylinder Rod Mount Bracket to the row cleaner frame using the supplied 5/8" X 1.75" GRD5 bolt ZN w/Thread Lock (13310G), 5/16-18 x 1.5 GRD 5 BOLT, two 5/16" washers, 5/16" ID x 5/8" OD bushing, and 5/16-18 TOP LOCK NUT

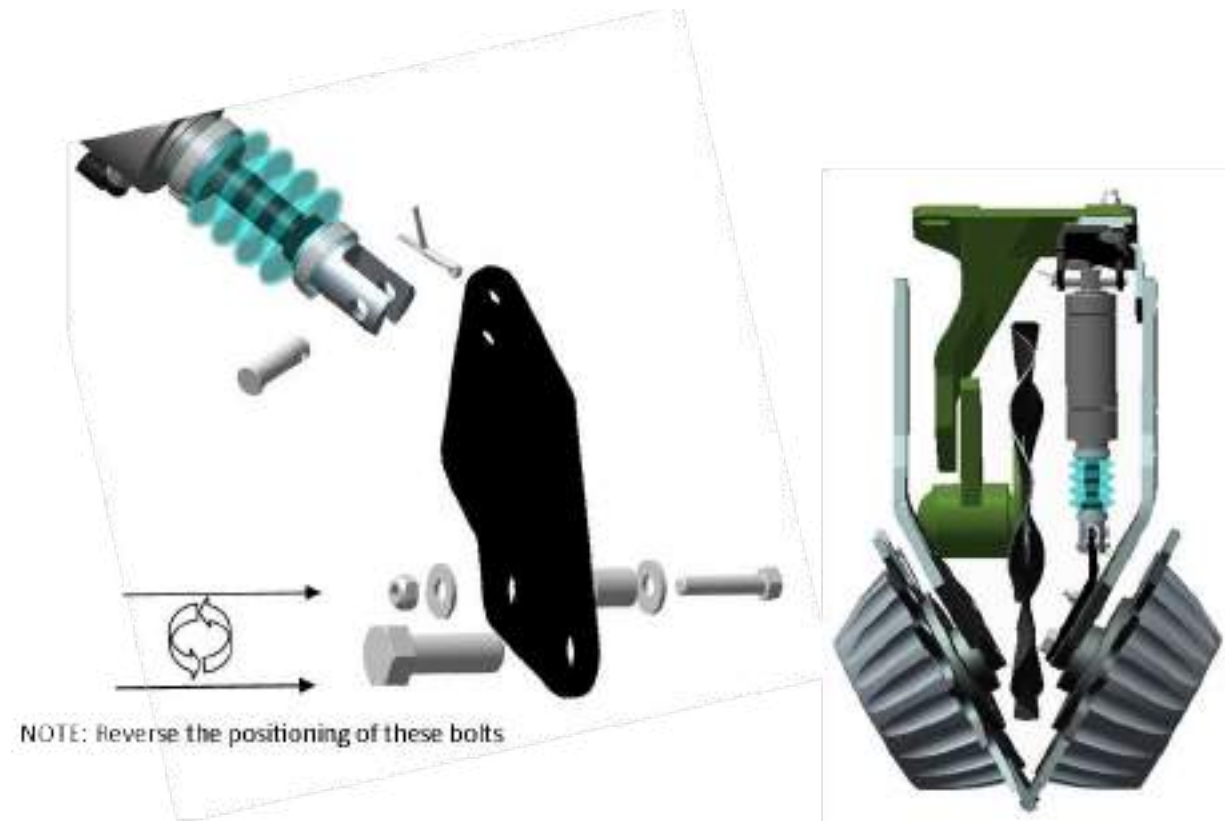

This will require removal of the existing 5/8" Bolt installed through the hub. When re-installing, re-use the existing 5/8" washer, ensure proper alignment of all components, and that the hub is firmly secured.

When installing the Cylinder Rod Mount Bracket, the first priority is to ensure proper alignment in the clevis yoke of the Rod. There may be considerable slop or play between the clevis yoke and the rod mounting bracket. This is OK and will not negatively affect the performance of the system. This is inherent in the U- Bolt fastener design and is intended to ease basic installation, especially on mildly deformed row cleaners. Pay close attention to the mounting location of this bracket. Consistent placement from row to row will provide consistent force from row to row and will prevent premature wear on the cylinder.

Secure the Rod Mounting Bracket to the clevis yoke on the cylinder using the supplied cylinder rod pivot pin (755019) and cotter pin. Refer to the Mounting Hole Selection guide at the end of this section for more information on which mounting holes to use with this bracket.

Ensure that the Row Cleaner does not 'hang' on the cylinder when extended. This may require extending the row cleaner until this situation is achieved, then selecting the pin location or stop bolt depth just above this depth.

Once the Rod Mounting Bracket has been properly aligned, secure the bracket by tightening the U- bolts to 30 lb-ft of torque.

Completed Cylinder Kit Installation



Maintenance Recommendations

If the bellows on the rubber boot become inverted or collapsed, locate the dimple on the rubber boot (near the Cylinder). Pinch the dimple open while articulating the Rod into and out of the Cylinder. This should allow the boot to re-seat properly.

Lubrication: Cylinders are manufactured with a non-migratory grease and should not require additional lubrication under normal operating conditions.

Mounting Hole Selection

Use this page to select the mounting location when using the Mounting Bracket — 755157

Note: The default mounting location is the TOP HOLE in the base mount and the TOP HOLE in the rod mount.

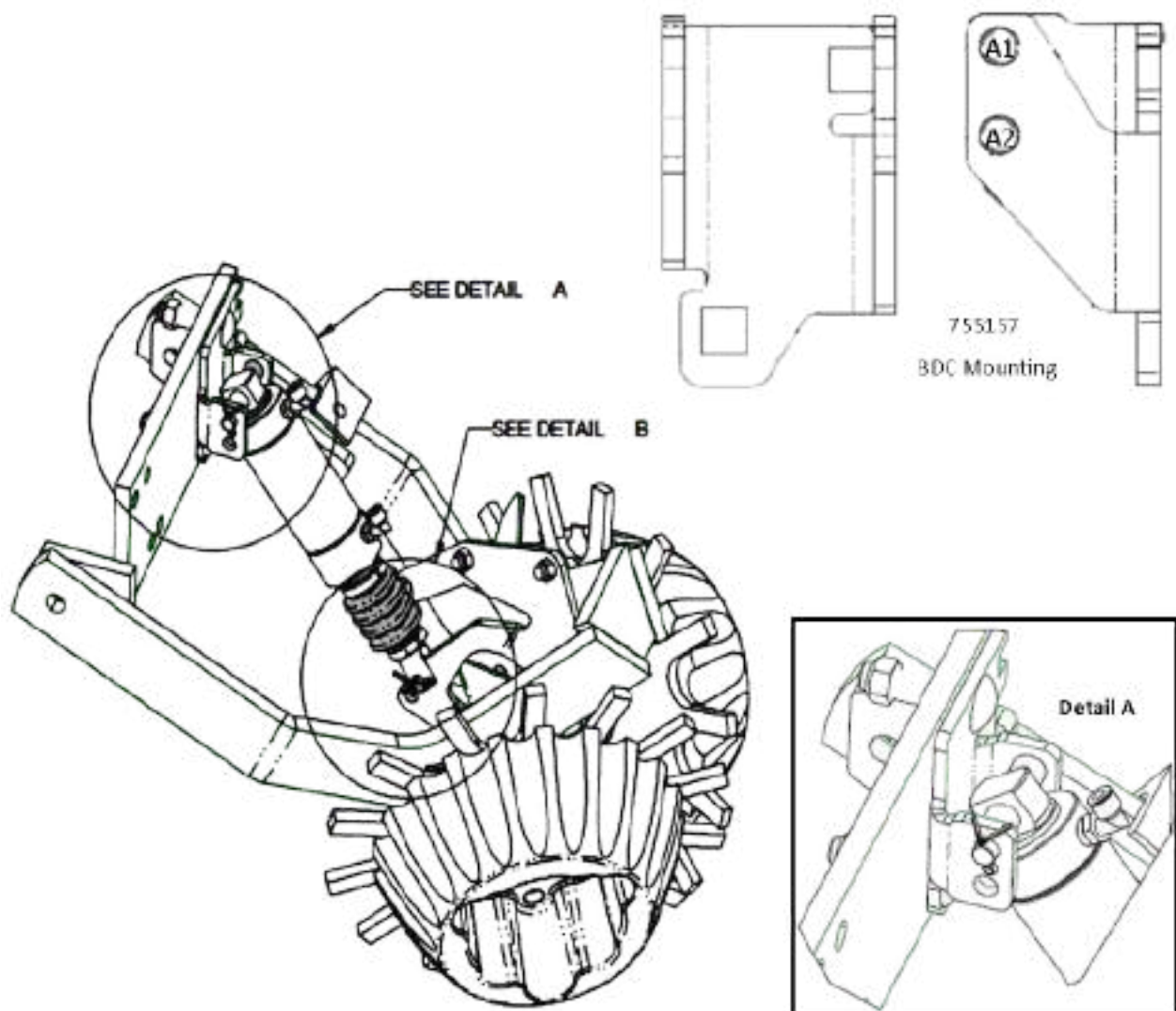

Hole A1 (Top Hole):

- Installing the cylinder in the top holes will INCREASE the magnitude of the force applies to the row cleaner. Therefore;
 - To be used if MORE down force is desired when the system will generally be used in the down direction.
 - To be used if LESS down force is desired when the system will generally be used in the lift direction.

Hole A2 (Bottom Hole):

- Installing the cylinder in the bottom holes will DECREASE the magnitude of the force applied to the row cleaner. Therefore;
 - To be used if LESS down force is desired when the system will generally be used in the down direction.
 - To be used in MORE down force is desired when the system will generally be used in the Lift direction.

The hole used on the Rod Mount Bracket should correspond to the same hole used on the Base Mount Bracket. Top to Top, Bottom to Bottom.

Note: In general, all rows will be set to the same hole. However, some rows may require unique settings. A typical example would be a row unit directly behind a tractor tire. In this example, this row unit should be set to exert more force on the row cleaner than the surrounding rows. If the system is normally operated in LIFT mode, install this row unit in the bottom hole. If the system is normally operated in the DOWN mode, install this row unit in the top hole.



Caution: Risk of hyper-extending the row cleaner/cylinder kit beneath the row unit. DO NOT run the stop bolt too deep. The row cleaner should not be allowed to fall below 38 degrees below horizontal; this usually equates to NO LESS than 3/4" of thread showing on the stop bolt below the stop bolt bracket

755210 — Yetter Titan 2967-029

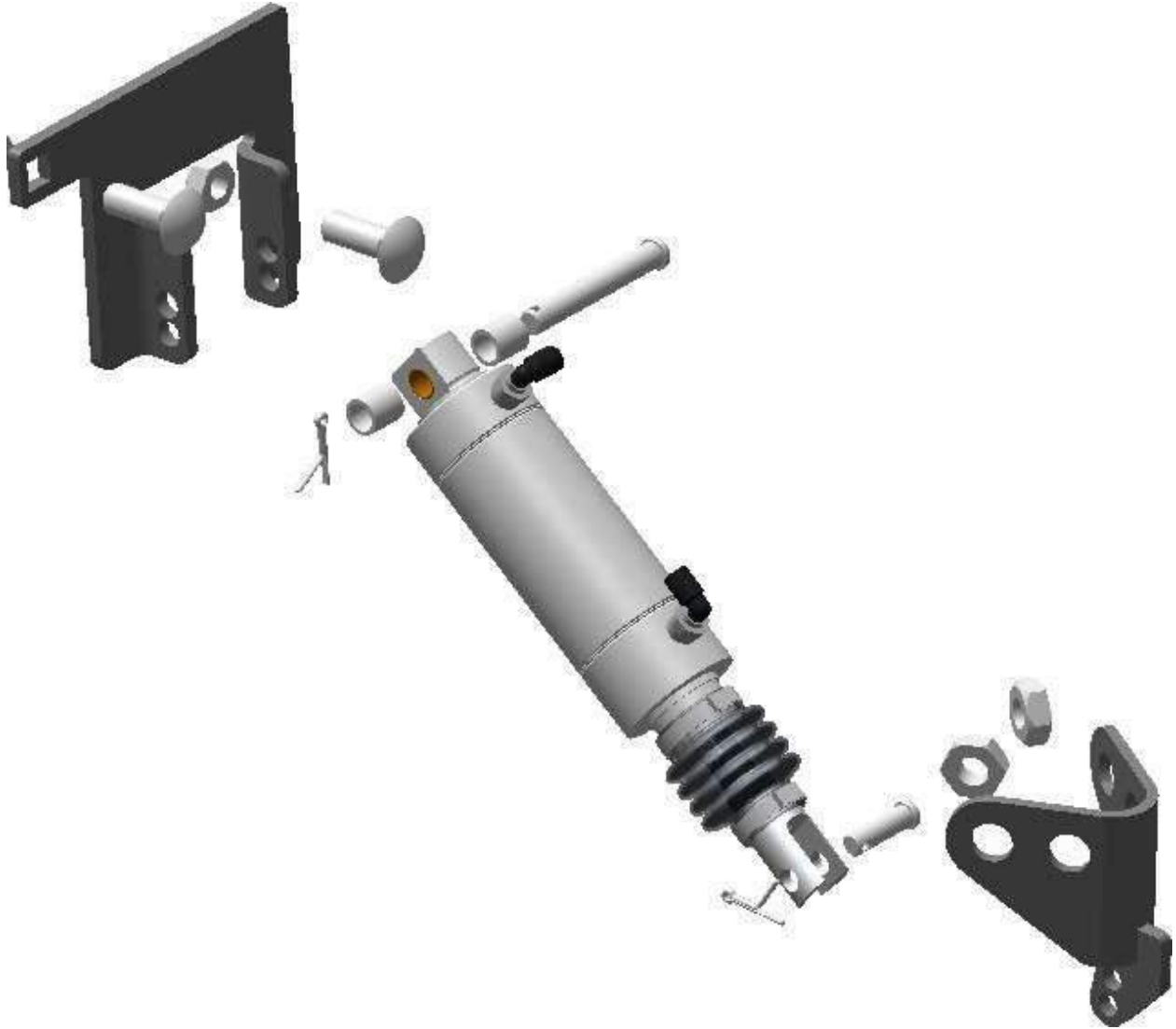

Notes and Compatibility Items

White 9000

- Mount cylinder base in the bottom hole of the bracket.

Kit Components

ITEM	QTY	PART NUMBER	PART NAME	DESCRIPTION
1	2	21824	Bolt, Round Head	1/2" x 1.5" GRD5 Carriage
2	2	37268	Hex Nut	1/2" Top Lock Hex Nut ZN
3	2	37273	Top Lock Jam Nut	5/8" GRD A ZN
4	2	755017	Spacer	5/8" OD X 7/16" ID X 0.688"L
5	1	755018	Pin	Cylinder Base Pivot
6	1	755019	Pin	Cylinder Rod Pivot
7	2	755028	Cotter Pin	1/8" X 1"
8	1	755176	Bracket	Cylinder Base Mount
9	1	755177	Bracket	Cylinder Rod Mount
10	1	755023	Air Cylinder	Complete Air Assembly (Sold Sep.)

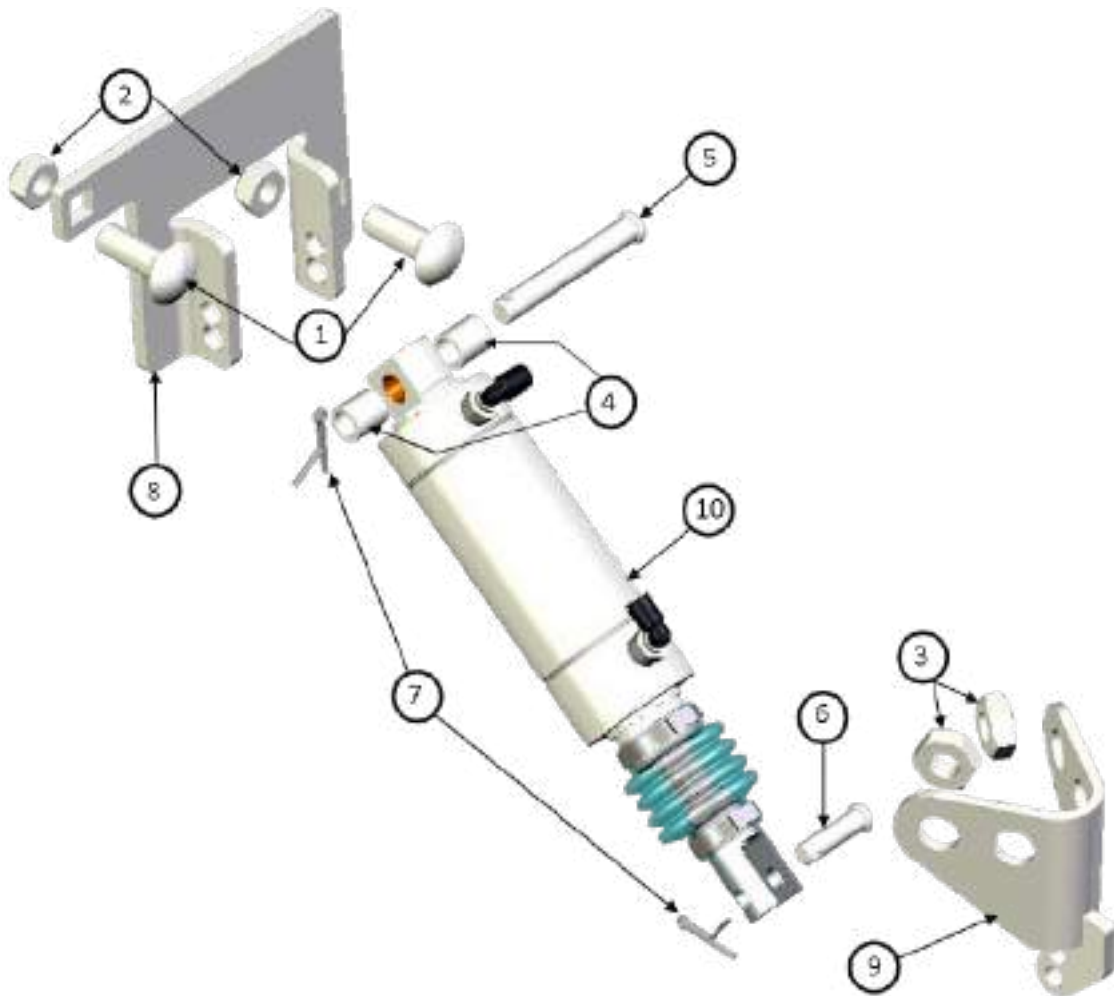

Installation

Note: This kit is for converting JD 7200/7300/17XX row units with Regular parallel arms (14") and/or Long parallel arms (21") with no coulter.

Step 1:

Secure the Cylinder Base Mounting Bracket to the face plate bracket using two - 1/2" X 1.5" Carriage Bolts and two - 1/2" Top Lock Hex Nuts.



Tighten to 75 lb-ft of torque.

Install the base of the Cylinder to this bracket using the Cylinder Base Pivot Pin (755018). Use the two -5/8" OD X 7/16ID X 0.688"L Spacer Bushings to properly secure and align the cylinder in the Base Mount Bracket.

The Default Pivot Hole for the Cylinder base in this conversion kit is the **BOTTOM HOLE**.

Refer to the Mounting Hole Selection guide at the end of this section for more information on which mounting holes to use with this bracket.

Step 2:

Install the Cylinder Rod Mounting Bracket to the row cleaner frame using the two - 5/8" GRD A ZN Top Lock Jam Nuts. This install will require the removal of the nut and washer present on the D-Bolt (serving as the axle) of the row cleaner. Re-install using the supplied 5/8" Nut and using the Mounting Bracket in place of the washer. Ensure proper alignment of all components, and that the hub is secured and returned to manufacturer's recommendations

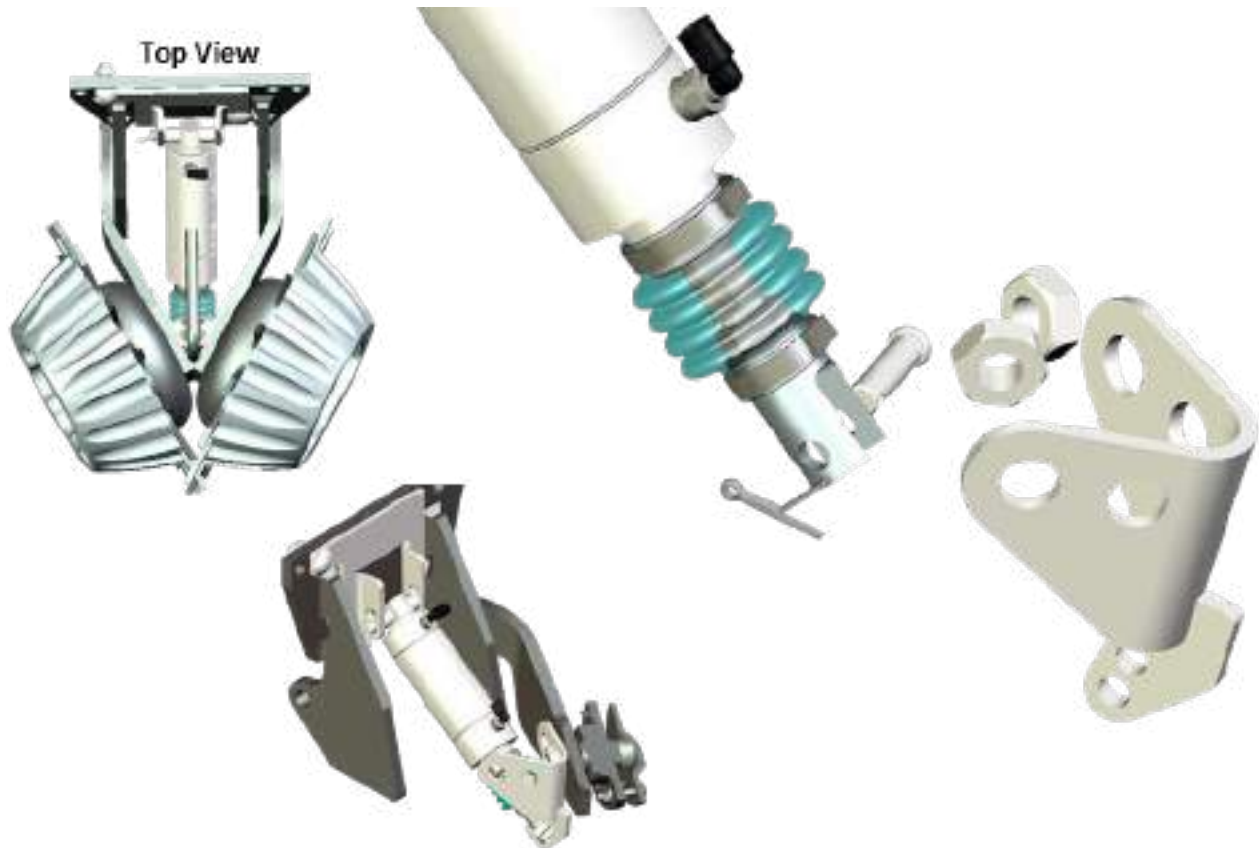

When installing the Cylinder Rod Mount Bracket, be sure it is properly aligned in the clevis yoke of the Rod and firmly seated in the curve of the row cleaner. This may require the exact angle of the bracket to be tweaked or modified in order to more perfectly match the individual row unit.

Secure the Rod Mounting Bracket to the clevis yoke on the cylinder using the supplied cylinder rod pivot pin (755019) and cotter pin.

The default Pivot Hole for the Cylinder Rod in this conversion kit is the **TOP HOLE**. Refer to the Mounting Hole Selection guide at the end of this section for more information on which mounting holes to use with this bracket.

When installing the Cylinder Rod Mount Bracket, the first priority is to ensure proper alignment in the clevis yoke of the Rod. There may be considerable slop or play between the clevis yoke and the rod mounting bracket. This is OK and will not negatively affect the performance of the system. This is intended to ease basic installation, especially on mildly deformed row cleaners. Pay close attention to the mounting location of this bracket. Consistent placement from row to row will provide consistent force from row to row and will prevent premature wear on the cylinder.

Verify the freedom of motion and clearance of components. Ensure that the Row Cleaner does not ‘hang’ on the cylinder when extended. This may require extending the row cleaner until this situation is achieved, then selecting the pin location or stop bolt depth just above this depth.

Completed Cylinder Kit Installation

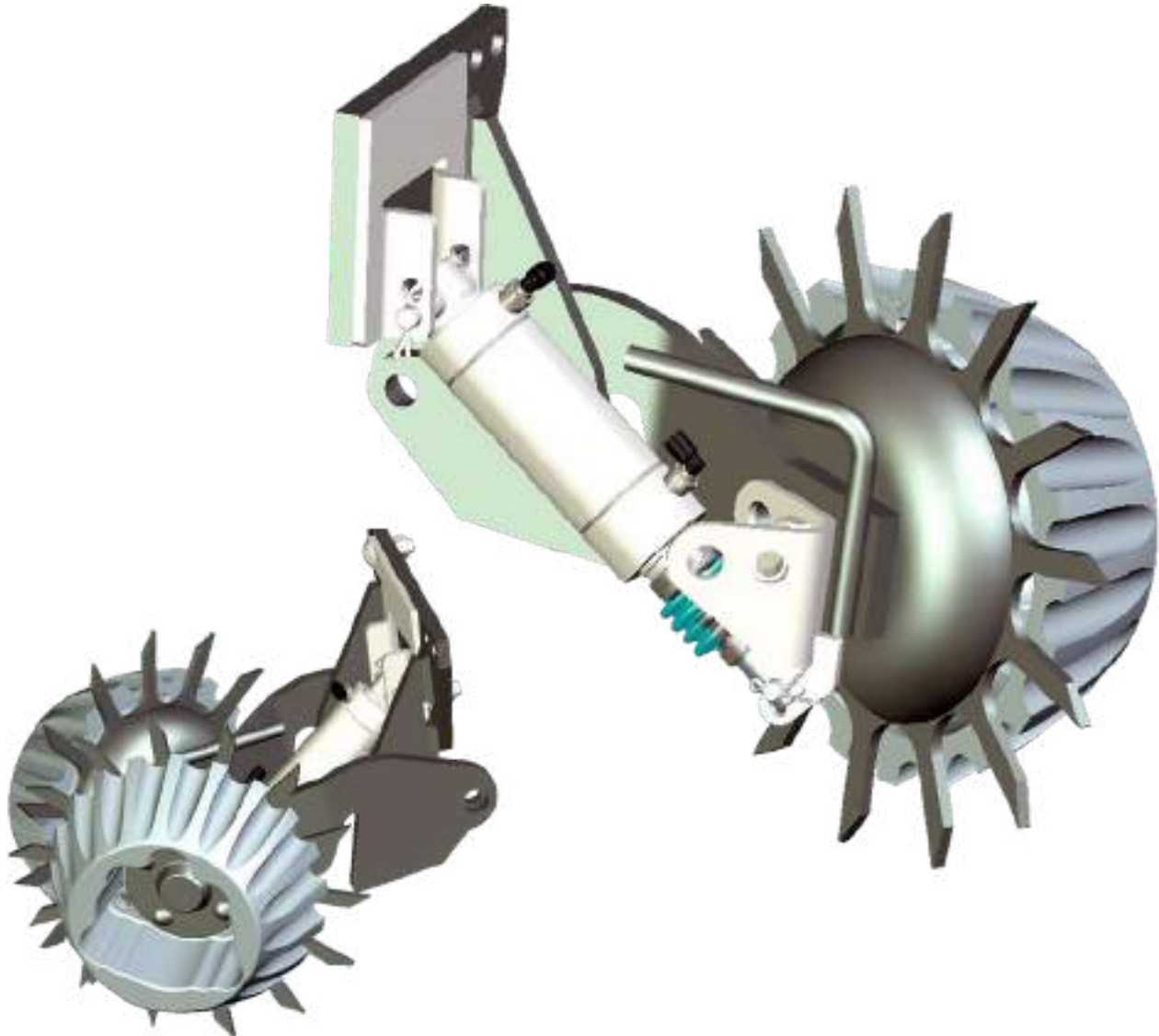

Maintenance Recommendations

If the bellows on the rubber boot become inverted or collapsed, locate the dimple on the rubber boot (near the Cylinder). Pinch the dimple open while articulating the Rod into and out of the Cylinder. This should allow the boot to re-seat properly.

Lubrication: Cylinders are manufactured with a non-migratory grease and should not require additional lubrication under normal operating conditions.

Mounting Hole Selection

Use this page to select the mounting location when using the Mounting Bracket — 755157

Note: The default mounting location for the Base bracket is the BOTTOM HOLE. The default mounting location for the Rod bracket is the TOP HOLE.

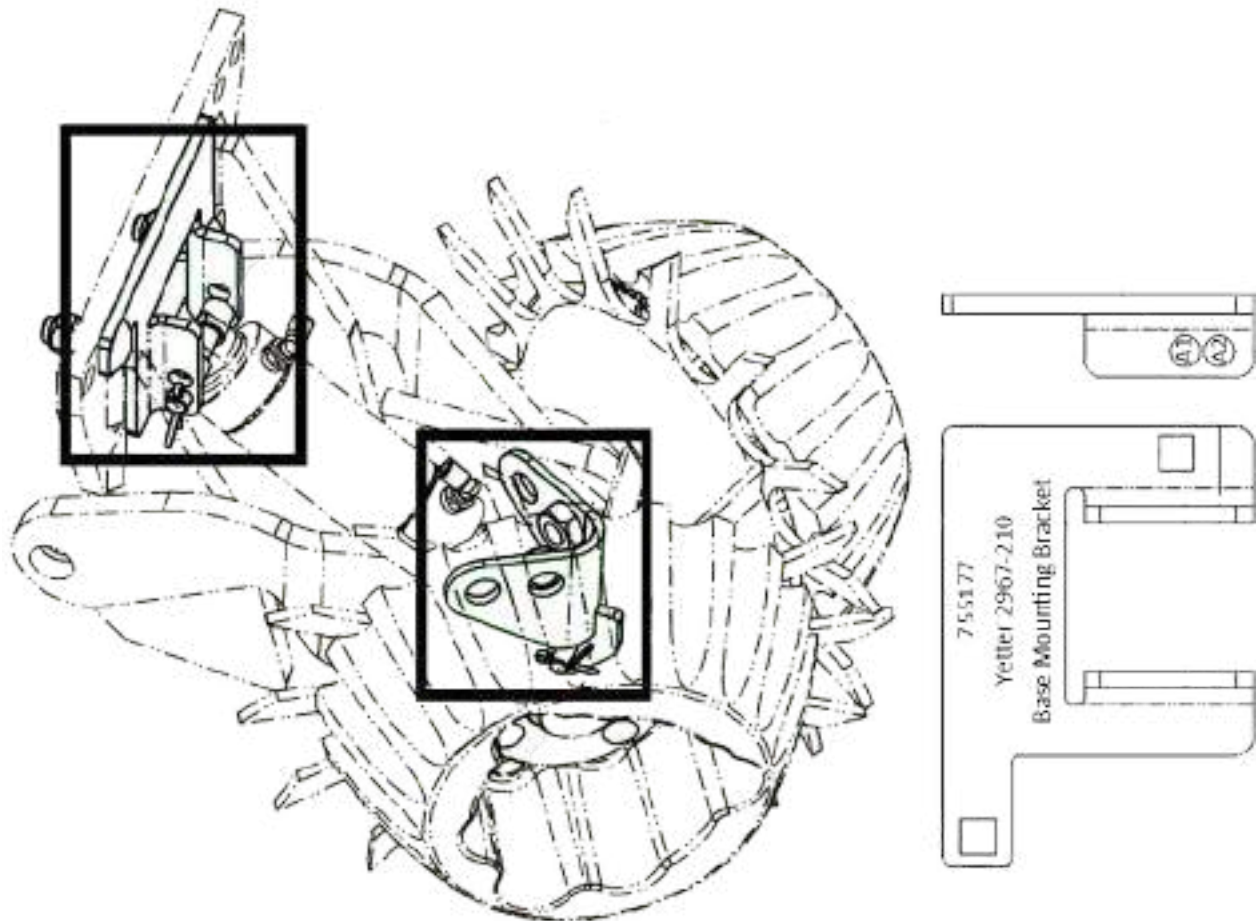

Hole A1 (Top Hole):

- Installing the cylinder in the top holes will INCREASE the magnitude of the force applies to the row cleaner. Therefore;
 - To be used if MORE down force is desired when the system will generally be used in the down direction.
 - To be used if LESS down force is desired when the system will generally be used in the lift direction.

Hole A2 (Bottom Hole):

- Installing the cylinder in the bottom holes will DECREASE the magnitude of the force applied to the row cleaner. Therefore;
 - To be used if LESS down force is desired when the system will generally be used in the down direction.
 - To be used in MORE down force is desired when the system will generally be used in the Lift direction.

Note: In general, all rows will be set to the same hole. However, some rows may require unique settings. A typical example would be a row unit directly behind a tractor tire. In this example, this row unit should be set to exert more force on the row cleaner than the surrounding rows. If the system is normally operated in LIFT mode, install this row unit in the bottom hole. If the system is normally operated in the DOWN mode, install this row unit in the top hole.



Caution: Risk of hyper-extending the row cleaner/cylinder kit beneath the row unit. DO NOT run the stop bolt too deep. The row cleaner should not be allowed to fall below 38 degrees below horizontal; this usually equates to NO LESS than 3/4" of thread showing on the stop bolt below the stop bolt bracket

755225 — Martin MTR (Low Mount Option)

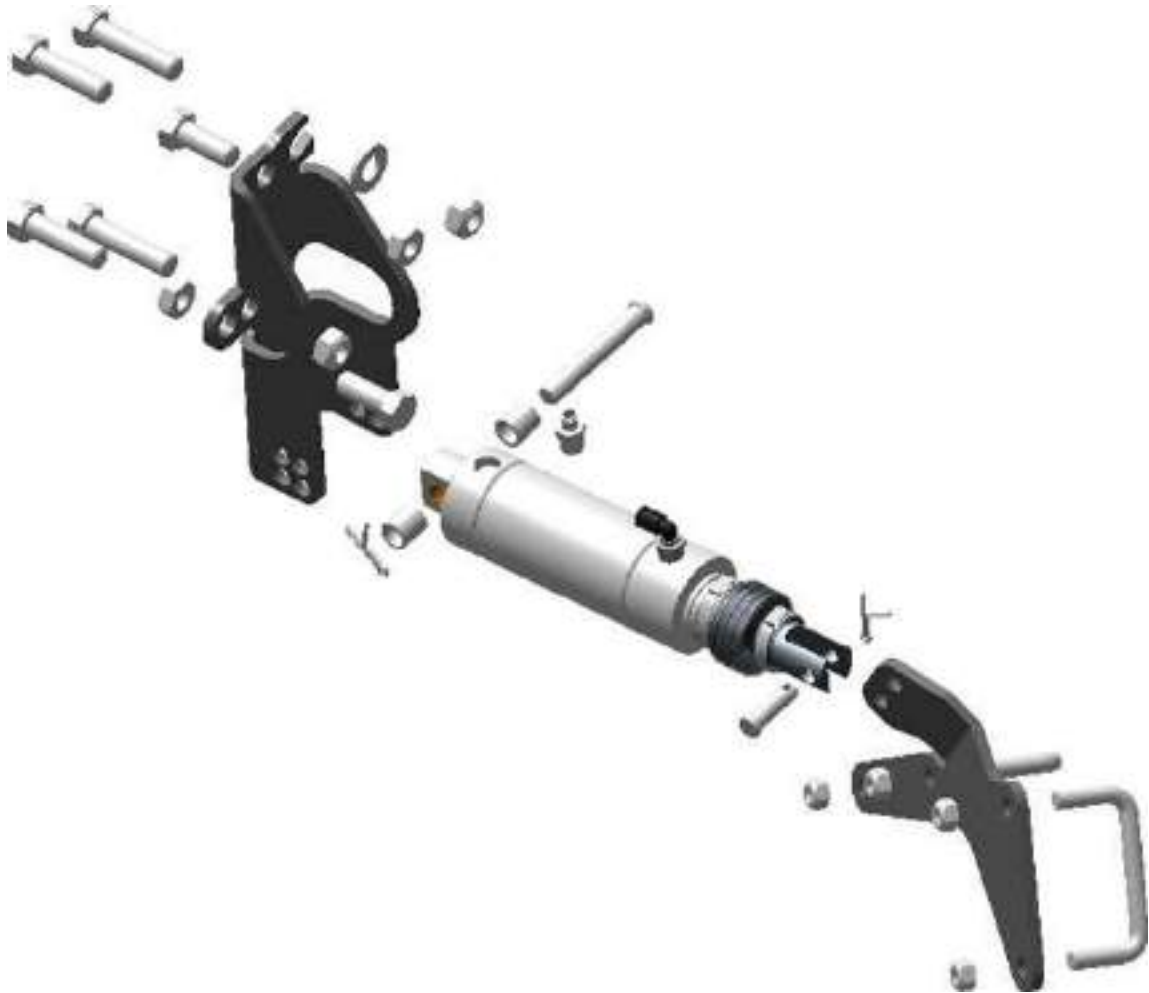

Notes and Compatibility Items

JD 7000/7100, White 5000/6000/8000, Case IH 12x0

- Only compatible if the row cleaners are mounted in the rear pivot holes on the row cleaner base as shown in the following pages.

Case IH 12x5

- CleanSweep is not compatible with Case lower parallel arm.

Case IH 12x5 with DeltaForce installed

- Only compatible if the row cleaners are mounted in the rear pivot holes on the row cleaner base as shown in the following pages.

Kit Components

ITEM	QTY	PART NUMBER	PART NAME	DESCRIPTION
1	2	13207	Bolt	1/2" X 1.25" GRD5 ZN Hex Head
2	2	13210	Bolt	1/2" X 1.75" GRD5 ZN Hex Head
3	2	13211	Bolt	1/2" X 2" GRD5 ZN Hex Head
4	1	33086	Washer	1/2" SAE Flat ZN
5	4	37264	Hex Nut	3/8" Top Lock Nut ZN
6	2	37268	Hex Nut	1/2" Top Lock Nut ZN
7	2	37269	Top Lock Jam Nut	1/2" GRD A ZN
8	1	726107	Fitting	1/4" NPT X 1/4" PTC
9	1	755006	Bracket	MTR Cylinder Rod Mount
10	2	755007	U-Bolt	2.75" X 0.5" Plate
11	2	755017	Spacer	5/8" OD X 7/16" ID X 0.688" L
12	1	755018	Pin	Cylinder Base Pivot
13	1	755019	Pin	Rod Base Pivot
14	2	755028	Cotter Pin	1/8" 1"
15	1	755179	Bracket	MTR Cylinder Base Mount (Low)
16	1	755023	Air Cylinder	Complete Air Cylinder Assembly (Sold Sep.)

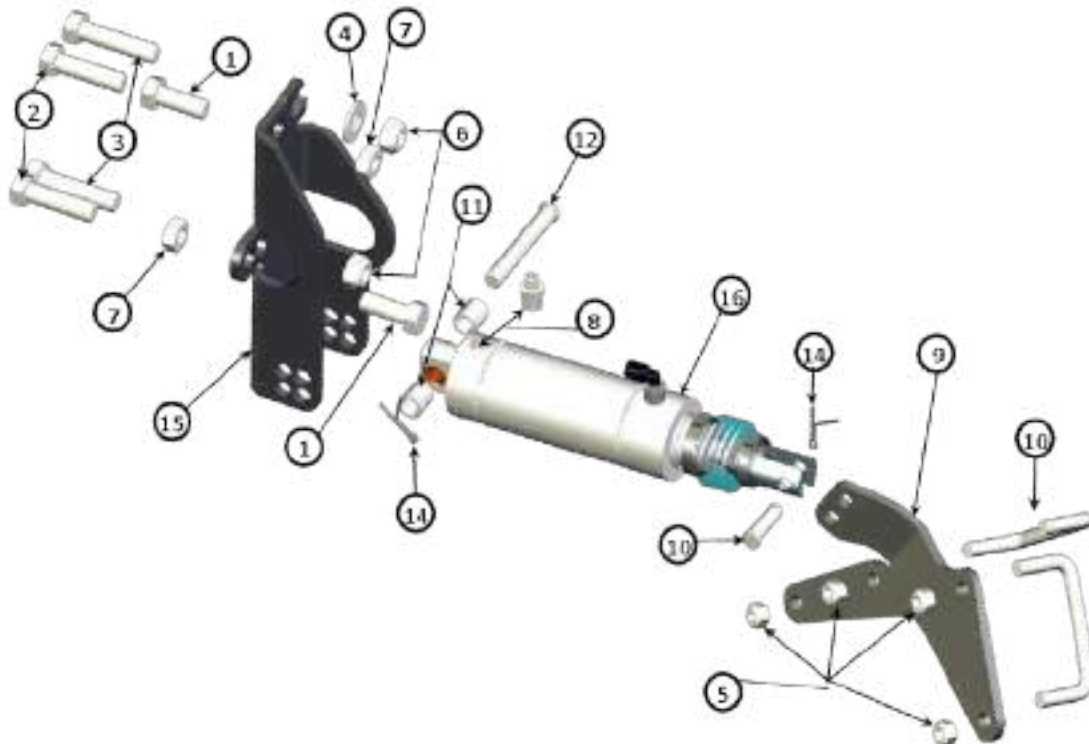

Installation

Note: This conversion kit is intended primarily for JD 7000, White, and Case row units with Martin C125 MTR; MTR-XP, MTR-81, & MTR-IH, and **IS** compatible with an installed coultter. This kit is also compatible with JD7200/7300/17XX and Kinze row units, however it is recommended that the 755195 brackets & hardware be used on those row units.

This conversion kit is compatible only if the row cleaner frame is mounted in the REAR pivot holes of the row cleaner base. See the image below.

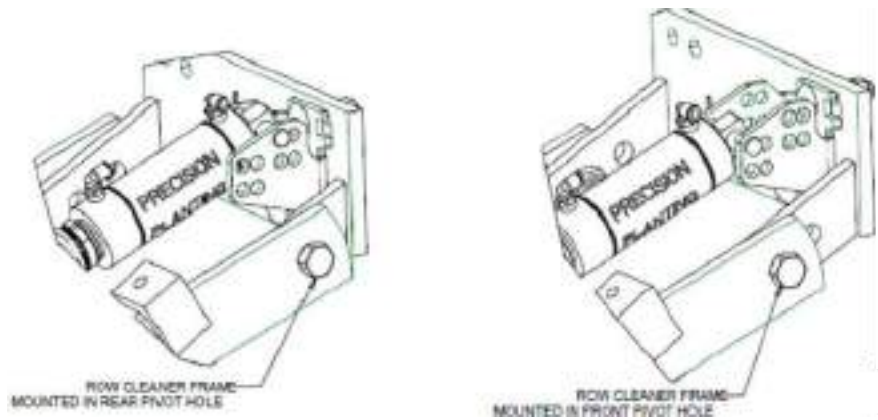

Step 1:

Secure the Cylinder Base Mounting Bracket to the face plate bracket.

JD 7000 & White Row Units:

- Coulter Installed: Mount using two — 1/2" X 2" GRD5 Hex Head Bolts and two — 1/2" Top Lock Hex Nuts.
- No Coulter installed: Mount using two — 1/2" X 1.75" GRD5 Hex Head Bolts and two — 1/2" Top Lock Hex Nuts.

Case Row Units:

- Mount using two — 1/2" X 1.25" carriage bolts and two — 1/2" Top Lock Jam Nuts GRD A ZN. This will allow clearance for gauge wheel rocker arms.

Tighten to 75 lb-ft of torque.

Bolt Selection	Coulter Installed Mount using: two— 1/2" X 2" Hex Head Bolts two— 1/2" Top Lock Hex Head Nuts
	No Coulter Installed Mount using: two— 1/2" X 1.75" Hex Head Bolts two— 1/2" Top Lock Hex Head Nuts
	One— 1/2" SAE Flat Washer When using the top right mount location (slot), ALWAYS use the supplied 1/2" SAE Flat Washer -top right bolt in far image-
Hole Selection	JD7000, Kinze, and White row units Normal installation will use the left most holes, top and bottom, of the bracket (towards the interior of the row unit)
	JD7200/7300/17XX row units Normal installation will use the right most holes, top and bottom, of the bracket (towards the exterior of the row unit)
Case Row Units	Mount using: two— 1/2" X 1.25" carriage bolts two— 1/2" Top Lock Jam Nuts This will allow clearance for gauge wheel rocker arms



Step 2:

Install the base of the Cylinder to this bracket using the Cylinder Base Pivot Pin (755018). Use the two -5/8" OD X 7/16ID X 0.688"L Spacer Bushings to properly secure and align the cylinder in the Base Mount Bracket. More information on which mounting holes to use with this bracket is covered on the next page as well as the Mounting Hole Selection guide.

This installation will require the removal of the 1/4"NPT X 1/4" PTC 90° Elbow from the Air Cylinder. Replace this fitting with the supplied 1/4"NPT X 1/4" PTC Straight Fitting. This will route the air lines in the safest method possible.



Step 3:

Install the Cylinder Rod Mounting Bracket to the row cleaner frame using the supplied 2.75" X 1/2" U-bolts (755007) and four - 3/8" Top Lock Hex Nuts (37264). Finger tighten only at this time; DO NOT tighten until the cylinder has been properly aligned.

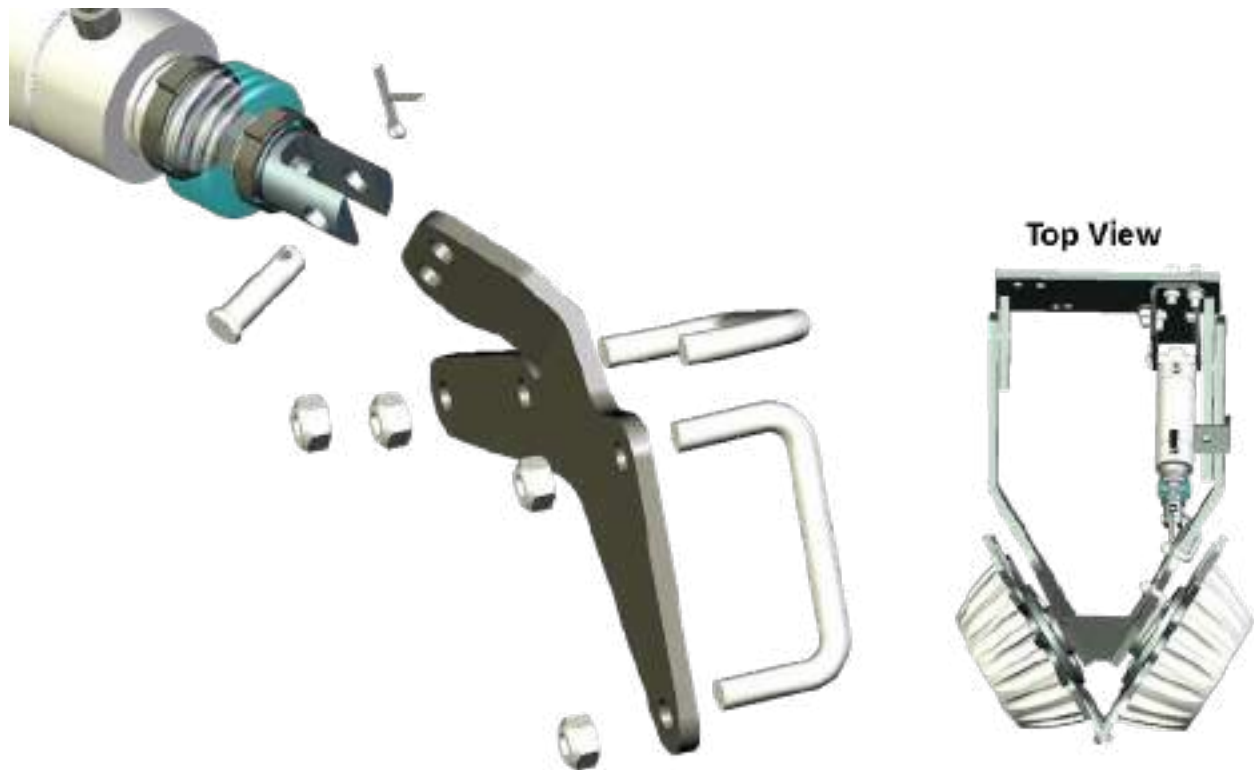

When installing the Cylinder Rod Mount Bracket, the first priority is to ensure proper alignment in the clevis yoke of the Rod. There may be considerable slop or play between the clevis yoke and the rod mounting bracket. This is OK and will not negatively affect the performance of the system. This is inherent in the U-Bolt fastener design and is intended to ease basic installation, especially on mildly deformed row cleaners. Pay close attention to the mounting location of this bracket. Consistent placement from row to row will provide consistent force from row to row and will prevent premature wear on the cylinder.

Secure the Rod Mounting Bracket to the clevis yoke on the cylinder using the supplied cylinder rod pivot pin (755019) and cotter pin. The default cylinder hole is the BOTTOM HOLE in the bracket.

Once the Rod Mounting Bracket has been properly aligned, secure the bracket by tightening the U-bolts to 30 lb-ft of torque.

Ensure that the Row Cleaner does not 'hang' on the cylinder when extended. This may require extending the row cleaner until this situation is achieved, then selecting the pin location or stop bolt depth just above this depth.

Completed Cylinder Kit Installation

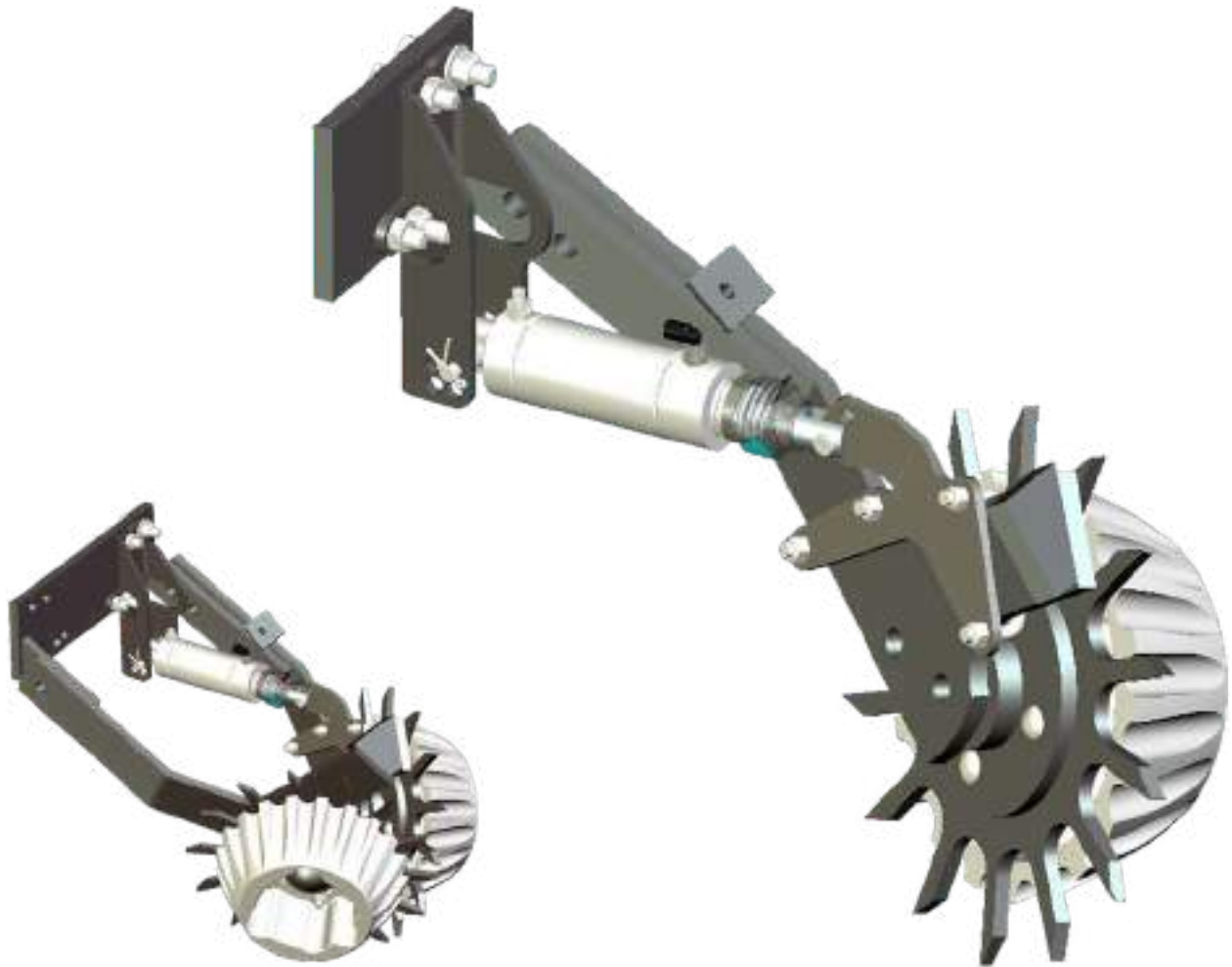

Maintenance Recommendations

If the bellows on the rubber boot become inverted or collapsed, locate the dimple on the rubber boot (near the Cylinder). Pinch the dimple open while articulating the Rod into and out of the Cylinder. This should allow the boot to re-seat properly.

Lubrication: Cylinders are manufactured with a non-migratory grease and should not require additional lubrication under normal operating conditions.

Mounting Hole Selection

Use this page to select the mounting location when using the Mounting Bracket — 755179



A Range Holes:

- Use on JD7000 and White row units with **NO COULTER** installed and **ALL** Case row units. This range should be used when the 755179 bracket is mounted directly to the row cleaner face plate bracket.

B Range Holes:

- Use on JD7000 and White row units when a unit mounted coultter **IS** installed. This range should be used when the 755179 bracket is mounted on top of another attachment.

Hole A1 (Top Hole):

- Installing the cylinder in the top holes will **DECREASE** the magnitude of the force applies to the row cleaner. Therefore;
 - To be used if **LESS** down force is desired when the system will generally be used in the down direction.
 - To be used if **MORE** down force is desired when the system will generally be used in the lift direction.

Hole A2 (Bottom Hole):

- Installing the cylinder in the bottom holes will **INCREASE** the magnitude of the force applied to the row cleaner. Therefore;
 - To be used if **MORE** down force is desired when the system will generally be used in the down direction.
 - To be used in **LESS** down force is desired when the system will generally be used in the Lift direction.

Note: In general, all rows will be set to the same hole. However, some rows may require unique settings. A typical example would be a row unit directly behind a tractor tire. In this example, this row unit should be set to exert more force on the row cleaner than the surrounding rows. If the system is normally operated in LIFT mode, install this row unit in the bottom hole. If the system is normally operated in the DOWN mode, install this row unit in the top hole.



Caution: Risk of hyper-extending the row cleaner/cylinder kit beneath the row unit. DO NOT run the stop bolt too deep. The row cleaner should not be allowed to fall below 38 degrees below horizontal; this usually equates to NO LESS than 3/4" of thread showing on the stop bolt below the stop bolt bracket

755230 — Yetter Titan 2967-035

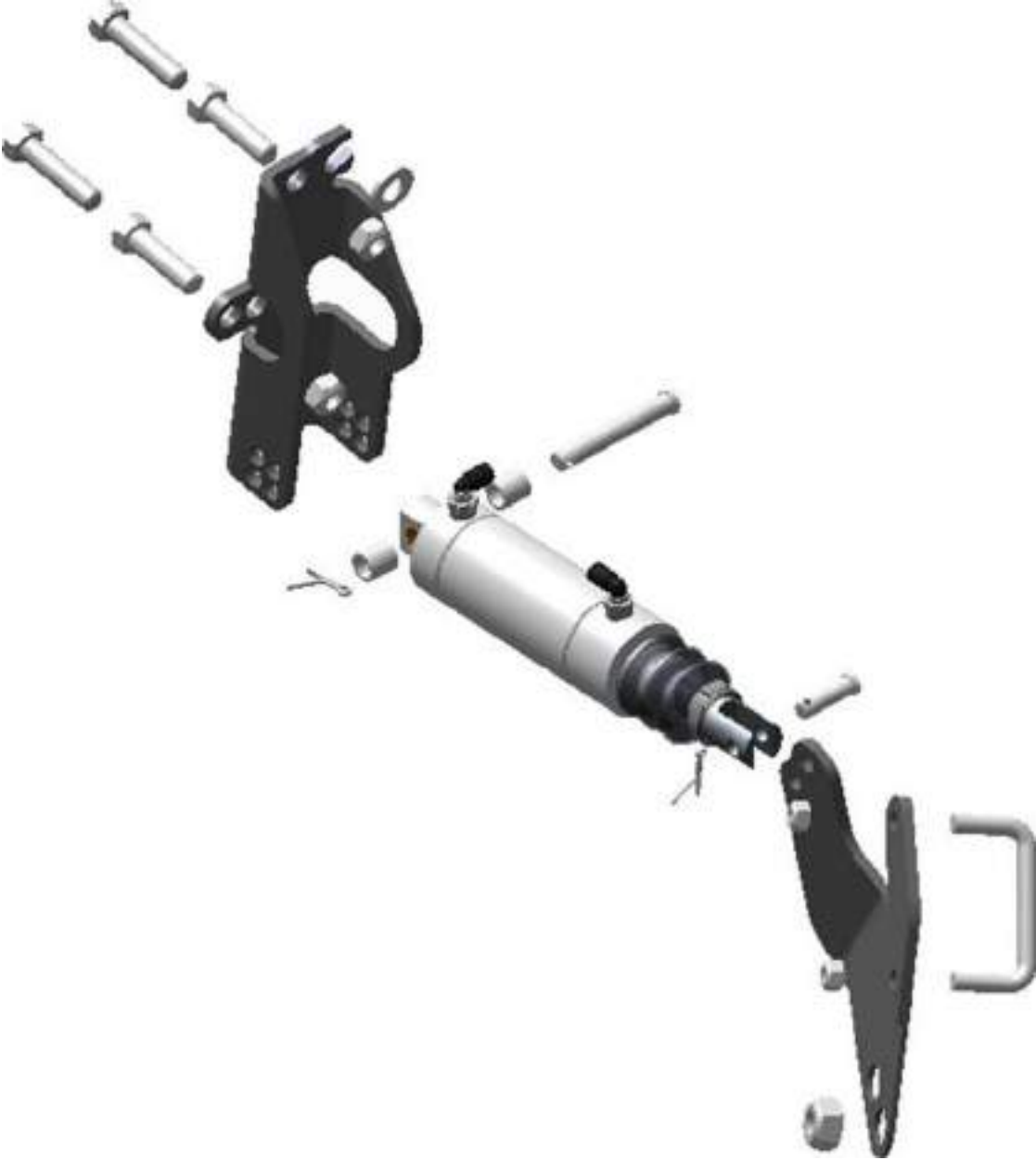

Kit Components

ITEM	QTY	PART NUMBER	PART NAME	DESCRIPTION
1	2	13210	Bolt	1/2" X 1.75" GRD5 ZN Hex Head ZN
2	2	13211	Bolt	1/2" X 2" GRD5 ZN Hex Head ZN
3	1	3386	Washer	1/2" SAE Flat Washer ZN
4	2	37264	Nut	3/8" Top Lock Nut ZN
5	2	37268	Nut	1/2" Top Lock Nut ZN
6	1	37272	Nut	5/8" Top Lock Nut ZN
7	1	726107	Fitting	1/4" NPT X 1/4" PTC Straight
8	1	755007	U-Bolt	2.75" X 0.5" Plate
9	2	755017	Spacer	5/8" OD X 7/16" ID X 0.688" L
10	1	755018	Pin	Cylinder Base Pivot
11	1	755019	Pin	Cylinder Rod Pivot
12	1	755022	Bracket	Cylinder Rod Mount 2967-035
13	2	755028	Cotter Pin	1/8" X 1"
14	1	755179	Bracket	MTR Cylinder Base Mount (Low)
15	1	755023	Air Cylinder	Complete Cylinder Assembly (Sold Sep.)

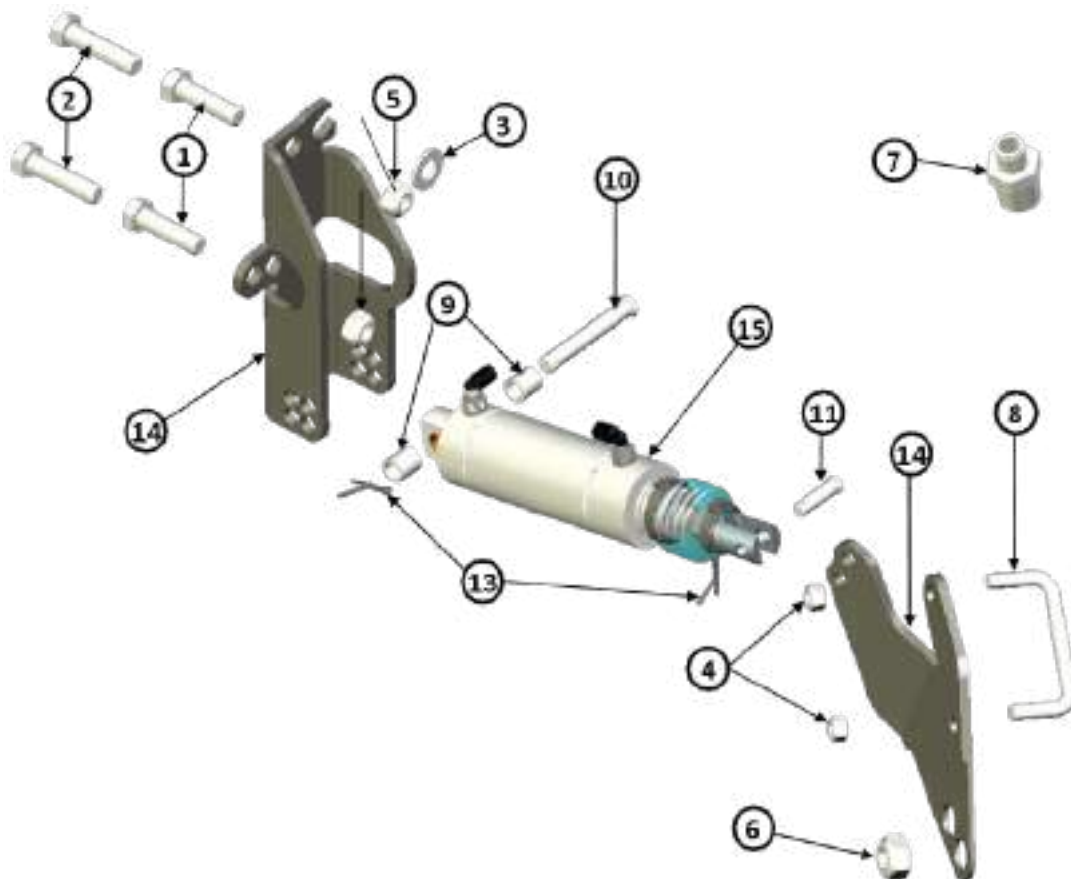

Installation

Note: This conversion kit is intended primarily for JD 7000, White, and Case row units with Martin C125 MTR; MTR-XP, MTR-81, & MTR-IH, and **IS**compatible with an installed coultter. This kit is also compatible with JD7200/7300/17XX and Kinze row units, however it is recommended that the 755195 brackets & hardware be used on those row units.

This conversion kit is compatible only if the row cleaner frame is mounted in the REAR pivot holes of the row cleaner base. See the image below.

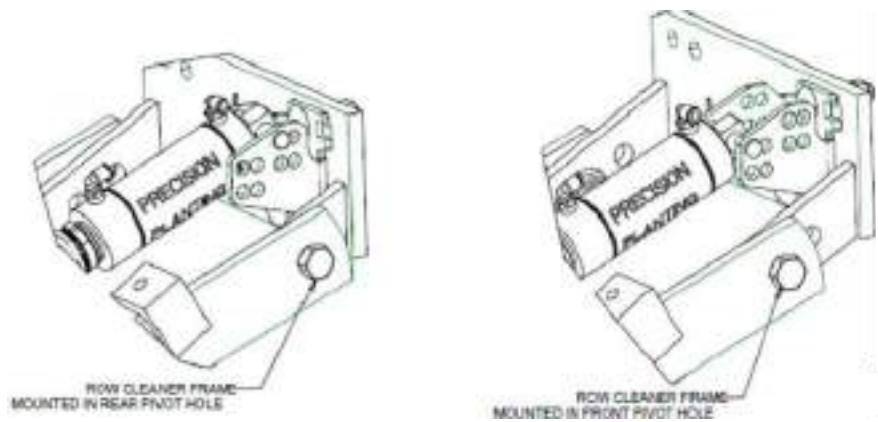

Step 1:

Secure the Cylinder Base Mounting Bracket to the face plate bracket.

JD 7000 & White Row Units:

- Coulter Installed: Mount using two — 1/2" X 2" GRD5 Hex Head Bolts and two — 1/2" Top Lock Hex Nuts.
- No Coulter installed: Mount using two — 1/2" X 1.75" GRD5 Hex Head Bolts and two — 1/2" Top Lock Hex Nuts.

Case Row Units:

- Mount using two — 1/2" X 1.25" carriage bolts and two — 1/2" Top Lock Jam Nuts GRD A ZN. This will allow clearance for gauge wheel rocker arms.

Tighten to 75 lb-ft of torque.

Bolt Selection	Coulter Installed Mount using: two— 1/2" X 2" Hex Head Bolts two— 1/2" Top Lock Hex Head Nuts
	No Coulter Installed Mount using: two— 1/2" X 1.75" Hex Head Bolts two— 1/2" Top Lock Hex Head Nuts
	One— 1/2" SAE Flat Washer When using the top right mount location (slot), ALWAYS use the supplied 1/2" SAE Flat Washer -top right bolt in far image-
Hole Selection	JD7000, Kinze, and White row units Normal installation will use the left most holes, top and bottom, of the bracket (towards the interior of the row unit)
	JD7200/7300/17XX row units Normal installation will use the right most holes, top and bottom, of the bracket (towards the exterior of the row unit)
	Case Row Units Mount using: two— 1/2" X 1.25" carriage bolts two— 1/2" Top Lock Jam Nuts This will allow clearance for gauge wheel rocker arms



Step 2:

Install the base of the Cylinder to this bracket using the Cylinder Base Pivot Pin (755018). Use the two -5/8" OD X 7/16ID X 0.688"L Spacer Bushings to properly secure and align the cylinder in the Base Mount Bracket. More information on which mounting holes to use with this bracket is covered on the next page as well as the Mounting Hole Selection guide.

This installation will require the removal of the 1/4"NPT X 1/4" PTC 90° Elbow from the Air Cylinder. Replace this fitting with the supplied 1/4"NPT X 1/4" PTC Straight Fitting. This will route the air lines in the safest method possible.



Step 3:

Install the Cylinder Rod Mounting Bracket to the row cleaner frame using the supplied 2.75" X 1/2" U-bolts (755007), two - 3/8" Top Lock Hex Nuts (37264) and one - 5/8" Top Lock Hex Nut. This install will require the removal of the nut and washer present on the D-Bolt (serving as the axle) of the row cleaner. Re-install using the supplied 5/8" Nut and using the Mounting Bracket in place of the washer. Ensure proper alignment of all components, and that the hub is secured and returned to manufacturer's recommendations.

Finger Tighten only at this time; DO NOT tighten until the cylinder has been properly aligned.

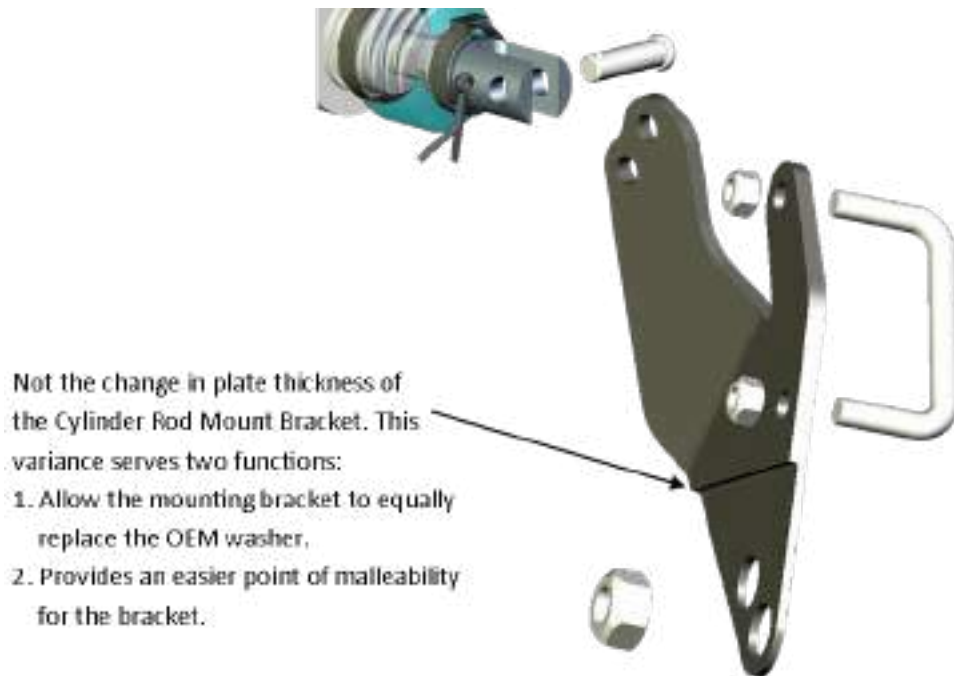

When installing the Cylinder Rod Mount Bracket, the first priority is to ensure proper alignment in the clevis yoke of the Rod. There may be considerable slop or play between the clevis yoke and the rod mounting bracket. This is OK and will not negatively affect the performance of the system. This is inherent in the U-Bolt fastener design and is intended to ease basic installation, especially on mildly deformed row cleaners. Pay close attention to the mounting location of this bracket. Consistent placement from row to row will provide consistent force from row to row and will prevent premature wear on the cylinder.

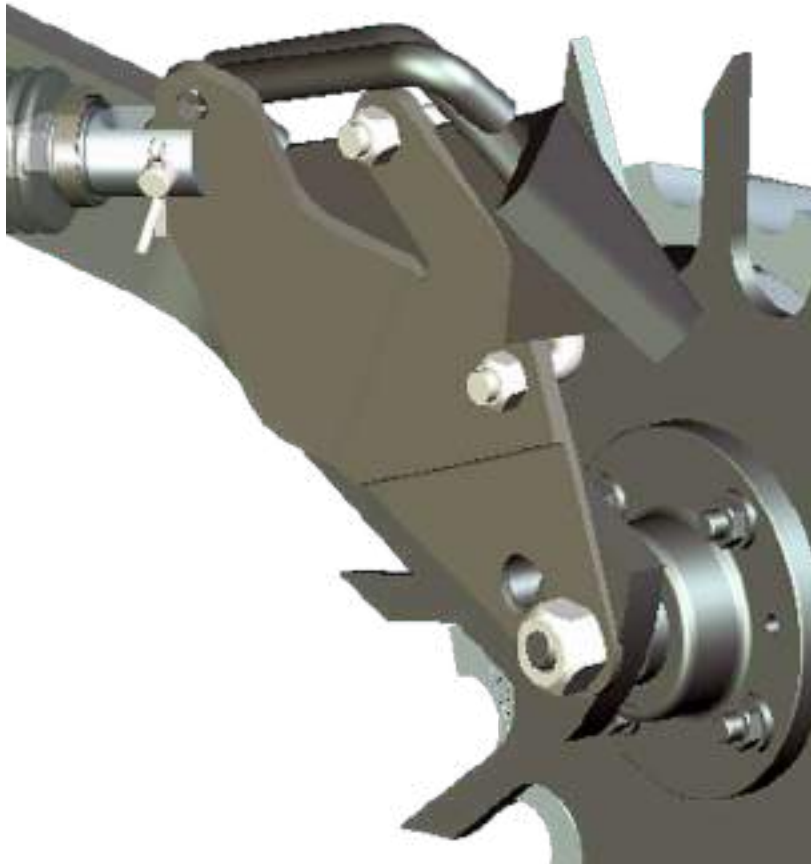

Secure the Rod Mounting Bracket to the clevis yoke on the cylinder using the supplied cylinder rod pivot pin (755019) and cotter pin. The default cylinder hole is the **BOTTOM HOLE** in the bracket.

Once the Rod Mounting Bracket has been properly aligned, secure the bracket by tightening the U-bolts to 30 lb-ft of torque.

Ensure that the Row Cleaner does not 'hang' on the cylinder when extended. This may require extending the row cleaner until this situation is achieved, then selecting the pin location or stop bolt depth just above this depth.

Verify the freedom of motion and clearance of components.

Completed Cylinder Kit Installation

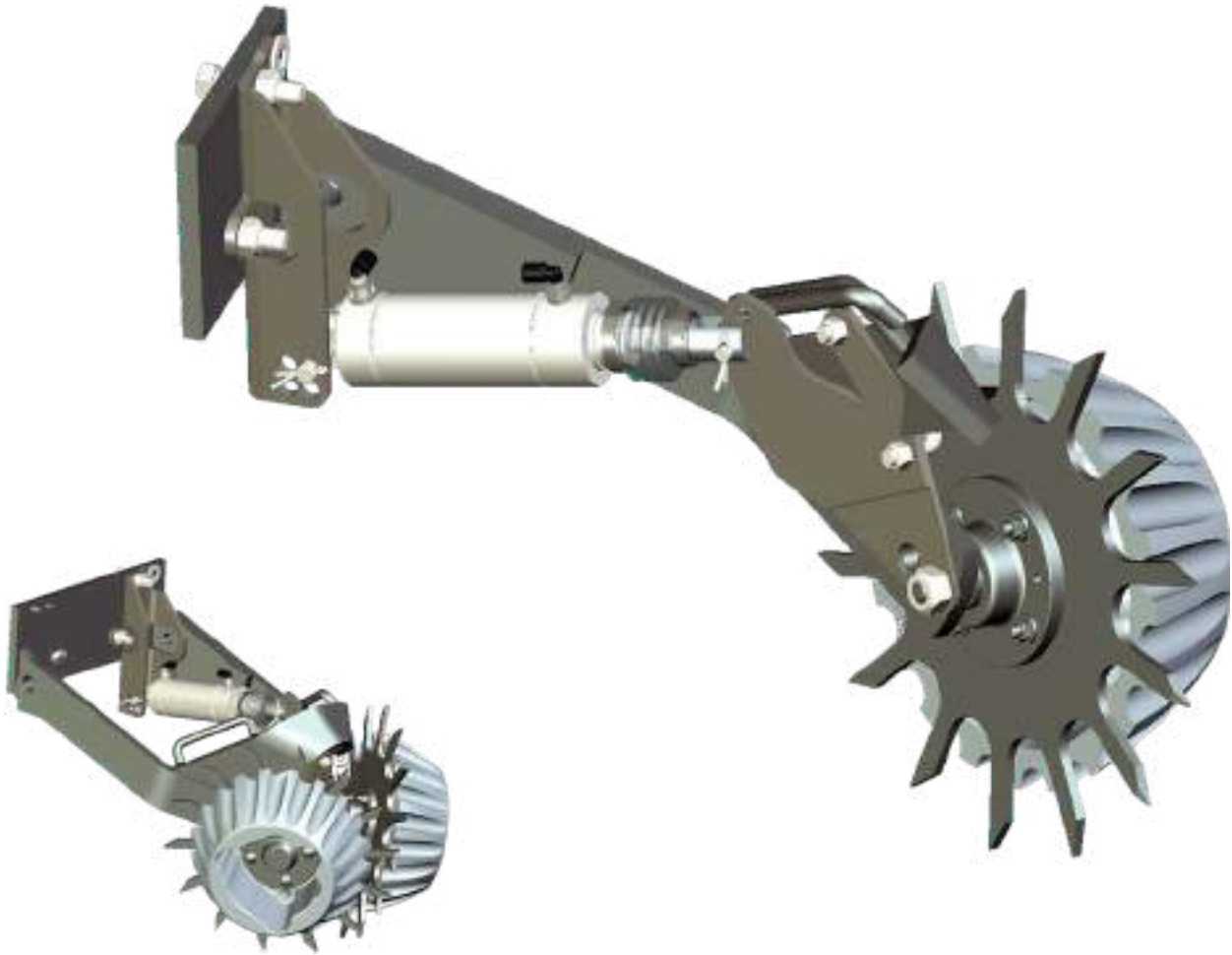

Maintenance Recommendations

If the bellows on the rubber boot become inverted or collapsed, locate the dimple on the rubber boot (near the Cylinder). Pinch the dimple open while articulating the Rod into and out of the Cylinder. This should allow the boot to re-seat properly.

Lubrication: Cylinders are manufactured with a non-migratory grease and should not require additional lubrication under normal operating conditions.

Mounting Hole Selection

Use this page to select the mounting location when using the Mounting Bracket — 755179



A Range Holes:

- Use on JD7000 and White row units with **NO COULTER** installed and **ALL** Case row units. This range should be used when the 755179 bracket is mounted directly to the row cleaner face plate bracket.

B Range Holes:

- Use on JD7000 and White row units when a unit mounted coultter **IS** installed. This range should be used when the 755179 bracket is mounted on top of another attachment.

Hole A1 (Top Hole):

- Installing the cylinder in the top holes will **DECREASE** the magnitude of the force applies to the row cleaner. Therefore;
 - To be used if **LESS** down force is desired when the system will generally be used in the down direction.
 - To be used if **MORE** down force is desired when the system will generally be used in the lift direction.

Hole A2 (Bottom Hole):

- Installing the cylinder in the bottom holes will **INCREASE** the magnitude of the force applied to the row cleaner. Therefore;
 - To be used if **MORE** down force is desired when the system will generally be used in the down direction.
 - To be used in **LESS** down force is desired when the system will generally be used in the Lift direction.

Note: In general, all rows will be set to the same hole. However, some rows may require unique settings. A typical example would be a row unit directly behind a tractor tire. In this example, this row unit should be set to exert more force on the row cleaner than the surrounding rows. If the system is normally operated in LIFT mode, install this row unit in the bottom hole. If the system is normally operated in the DOWN mode, install this row unit in the top hole.



Caution: Risk of hyper-extending the row cleaner/cylinder kit beneath the row unit. DO NOT run the stop bolt too deep. The row cleaner should not be allowed to fall below 38 degrees below horizontal; this usually equates to NO LESS than 3/4" of thread showing on the stop bolt below the stop bolt bracket

755245 — Yetter Titan 2967-097



Notes and Compatibility Items

Case IH 12x5 with Precision Planting DeltaForce

- Stop Kit (755231) must be ordered separately and installed to prevent damage to CleanSweep cylinder.

Kit Components

ITEM	QTY	PART NUMBER	PART NAME	DESCRIPTION
1	1	13225	Bolt	1/2" x 6" GRD 5
2	1	36310	Hex Nut	1/2" Top Hex Nut ZN
3	2	37273	Top Lock Jam Nut	5/8" —11 GRD A ZN
4	2	755017	Spacer	5/8" OD X 7/16" ID X 0.688"L
5	1	755018	Pin	Cylinder Base Pivot
6	1	755019	Pin	Cylinder Rod Pivot
7	2	755028	Cotter Pin	1/8" X 1"
8	1	755177	Bracket	Cylinder Base Mount
9	1	755208	Bracket	Cylinder Rod Mount
10	1	755023	Air Cylinder	Complete Air Assembly (Sold Sep.)

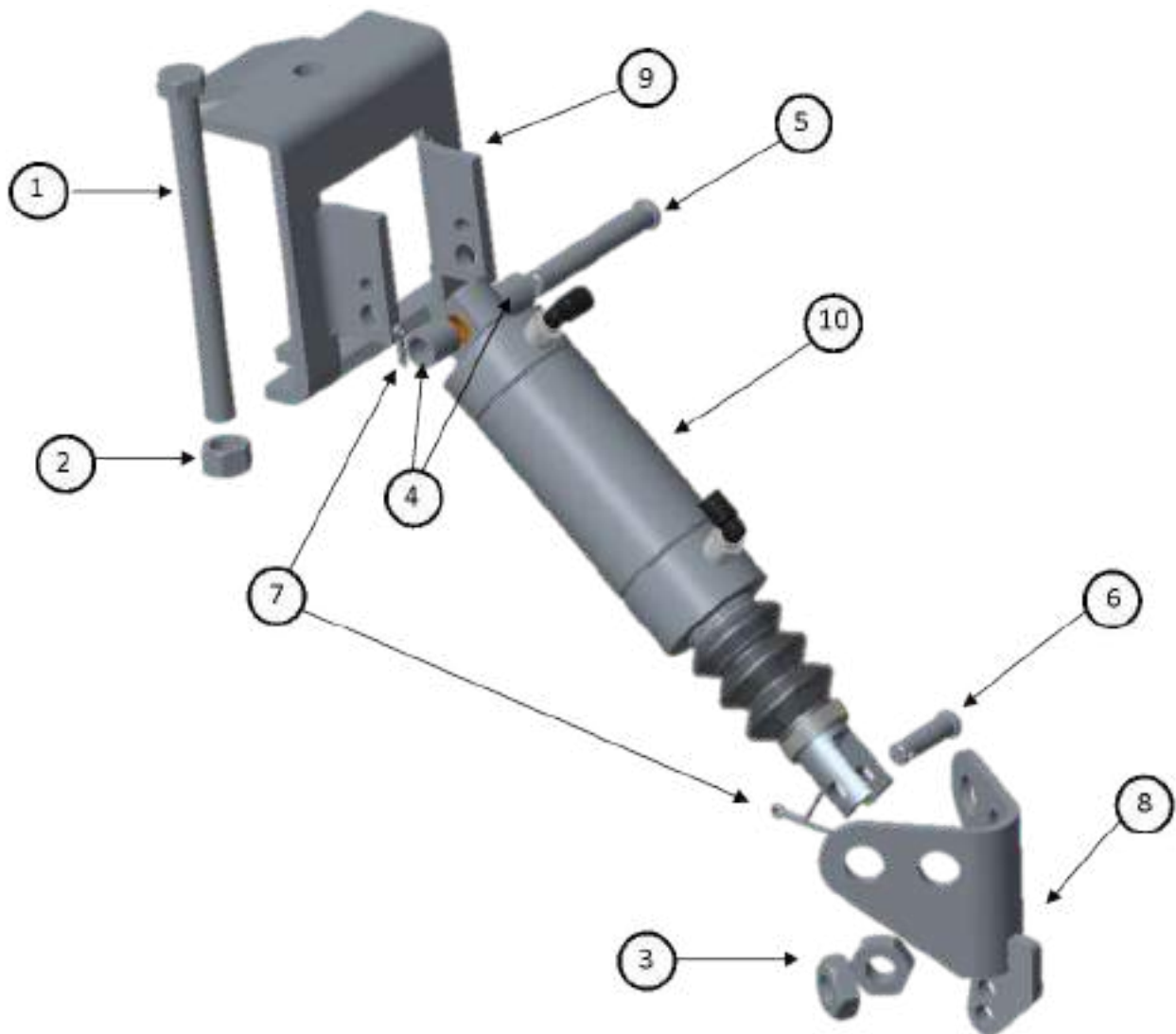

Installation

Step 1:

First, install the cylinder onto the base bracket using the cylinder base pivot pin (755018) and cotter pin.

Secure the base brackets to the face plate with the 1/2" x 6" bolt and the 1/2" hex nut.

Use the two spacer bushings (755017) to secure and align the cylinder in the base mount bracket. The cylinder will be installed in the **BOTTOM HOLE**.

Do not use the top hole in this kit



Tighten to 75 lb-ft of torque.

Step 2:

Install the Cylinder Rod Mounting Bracket to the row cleaner frame using the two - 5/8" GRD A ZN Top Lock Jam Nuts. This install will require the removal of the nut and washer present on the D-Bolt (serving as the axle) of the row cleaner. Re-install using the supplied 5/8" Nut and using the Mounting Bracket in place of the washer. Ensure proper alignment of all components, and that the hub is secured and returned to manufacturer's recommendations.

When installing the Cylinder Rod Mount Bracket, be sure it is properly aligned in the clevis yoke of the Rod and firmly seated in the curve of the row cleaner. This may require the exact angle of the bracket to be tweaked or modified in order to more perfectly match the individual row unit.



Secure the Rod Mounting Bracket to the clevis yoke on the cylinder using the supplied cylinder rod pivot pin (755019) and cotter pin.

The default Pivot Hole for the Cylinder Rod in this conversion kit is the **TOP HOLE**. Refer to the Mounting Hole Selection guide at the end of this section for more information on which mounting holes to use with this bracket.

When installing the Cylinder Rod Mount Bracket, the first priority is to ensure proper alignment in the clevis yoke of the Rod. There may be considerable slop or play between the clevis yoke and the rod mounting bracket. This is OK and will not negatively affect the performance of the system. This is intended to ease basic installation, especially on mildly deformed row cleaners. Pay close attention to the mounting location of this bracket. Consistent placement from row to row will provide consistent force from row to row and will prevent premature wear on the cylinder.

Verify the freedom of motion and clearance of components. Ensure that the Row Cleaner does not 'hang' on the cylinder when extended. This may require extending the row cleaner until this situation is achieved, then selecting the pin location or stop bolt depth just above this depth.

Completed Cylinder Kit Installation

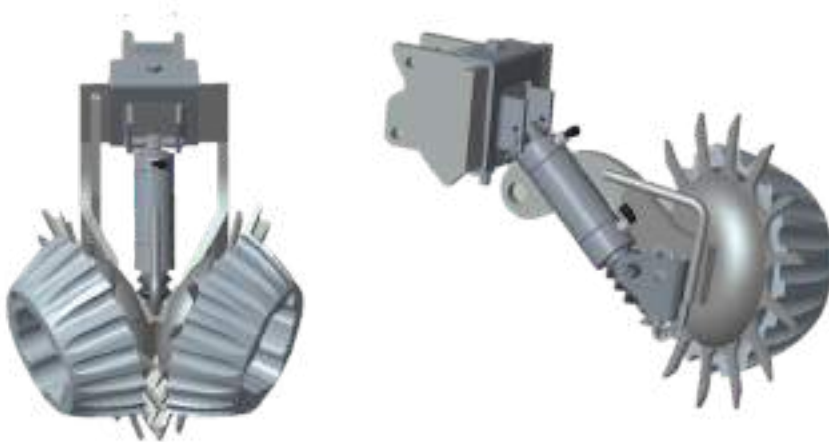

Maintenance Recommendations

If the bellows on the rubber boot become inverted or collapsed, locate the dimple on the rubber boot (near the Cylinder). Pinch the dimple open while articulating the Rod into and out of the Cylinder. This should allow the boot to re-seat properly.

Lubrication: Cylinders are manufactured with a non-migratory grease and should not require additional lubrication under normal operating conditions.

For all Case IH installations, route airlines as shown in Picture 1



Mounting Hole Selection

Use this page to select the mounting location when using the Mounting Bracket — 755157

Note: The default mounting location for the Base bracket is the BOTTOM HOLE. The default mounting location for the Rod bracket is the TOP HOLE.

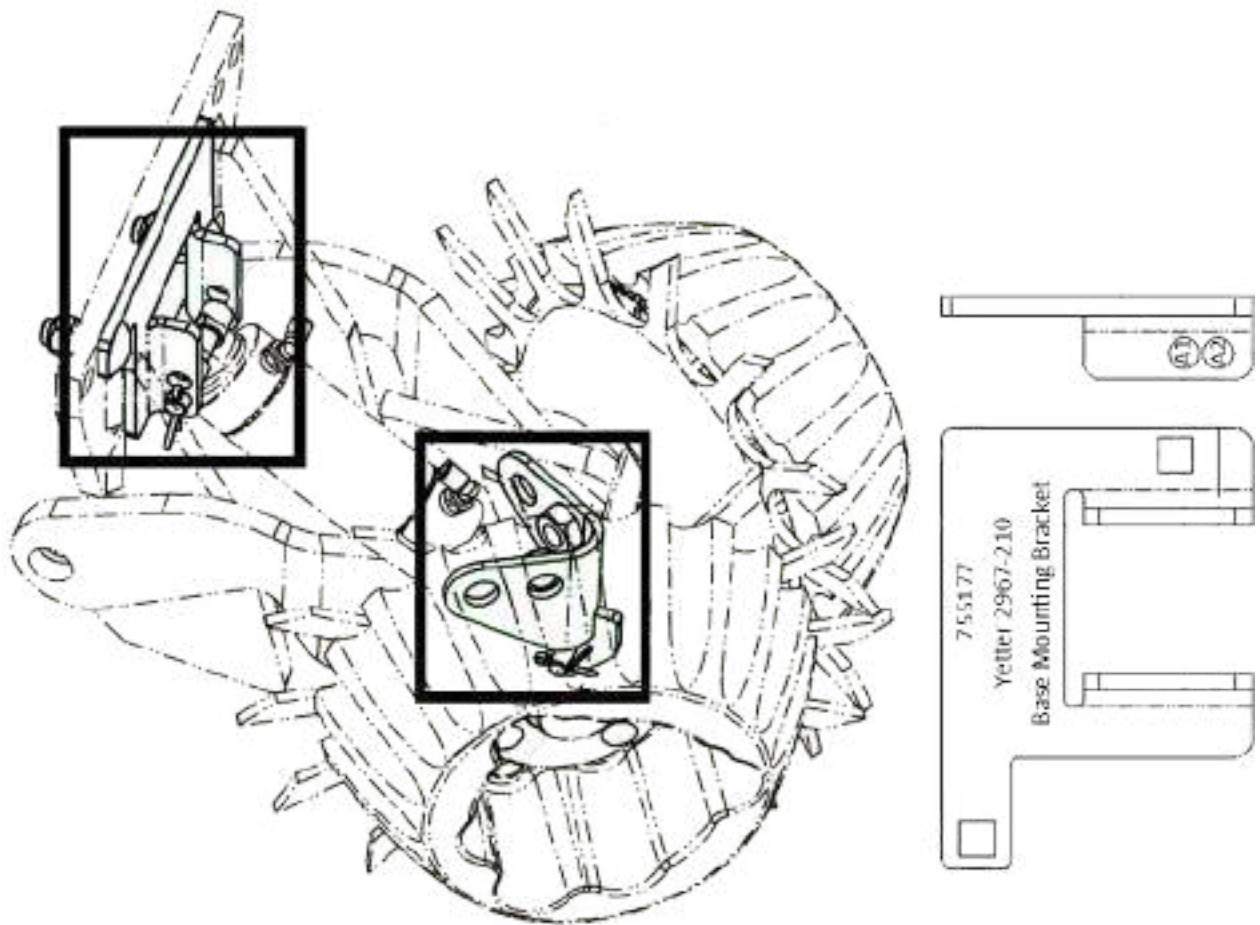

Hole A1 (Top Hole):

- Installing the cylinder in the top holes will INCREASE the magnitude of the force applies to the row cleaner. Therefore;
 - To be used if MORE down force is desired when the system will generally be used in the down direction.
 - To be used if LESS down force is desired when the system will generally be used in the lift direction.

Hole A2 (Bottom Hole):

- Installing the cylinder in the bottom holes will DECREASE the magnitude of the force applied to the row cleaner. Therefore;
 - To be used if LESS down force is desired when the system will generally be used in the down direction.
 - To be used in MORE down force is desired when the system will generally be used in the Lift direction.

Note: In general, all rows will be set to the same hole. However, some rows may require unique settings. A typical example would be a row unit directly behind a tractor tire. In this example, this row unit should be set to exert more force on the row cleaner than the surrounding rows. If the system is normally operated in LIFT mode, install this row unit in the bottom hole. If the system is normally operated in the DOWN mode, install this row unit in the top hole.



Caution: Risk of hyper-extending the row cleaner/cylinder kit beneath the row unit. DO NOT run the stop bolt too deep. The row cleaner should not be allowed to fall below 38 degrees below horizontal; this usually equates to NO LESS than 3/4" of thread showing on the stop bolt below the stop bolt bracket

755250 — Yetter Titan 2967-013/14 (Case Row Unit)



Notes and Compatibility Items

Case IH 12x5 with Precision Planting DeltaForce installed

- Stop kit (755231) must be ordered separately and installed to prevent damage to CleanSweep cylinder.

Kit Components

ITEM	QTY	PART NUMBER	PART NAME	DESCRIPTION
1	1	13225	Bolt	1/2" x 6" GRD 5
2	1	36310	Hex Nut	1/2" Top Hex Nut ZN
3	2	37273	Top Lock Jam Nut	5/8" —11 GRD A ZN
4	2	755017	Spacer	5/8" OD X 7/16" ID X 0.688"L
5	1	755018	Pin	Cylinder Base Pivot
6	1	755019	Pin	Cylinder Rod Pivot
7	2	755028	Cotter Pin	1/8" X 1"
8	1	755203	Bracket	Cylinder Base Mount
9	1	755208	Bracket	Cylinder Rod Mount
10	1	755023	Air Cylinder	Complete Air Assembly (Sold Sep.)

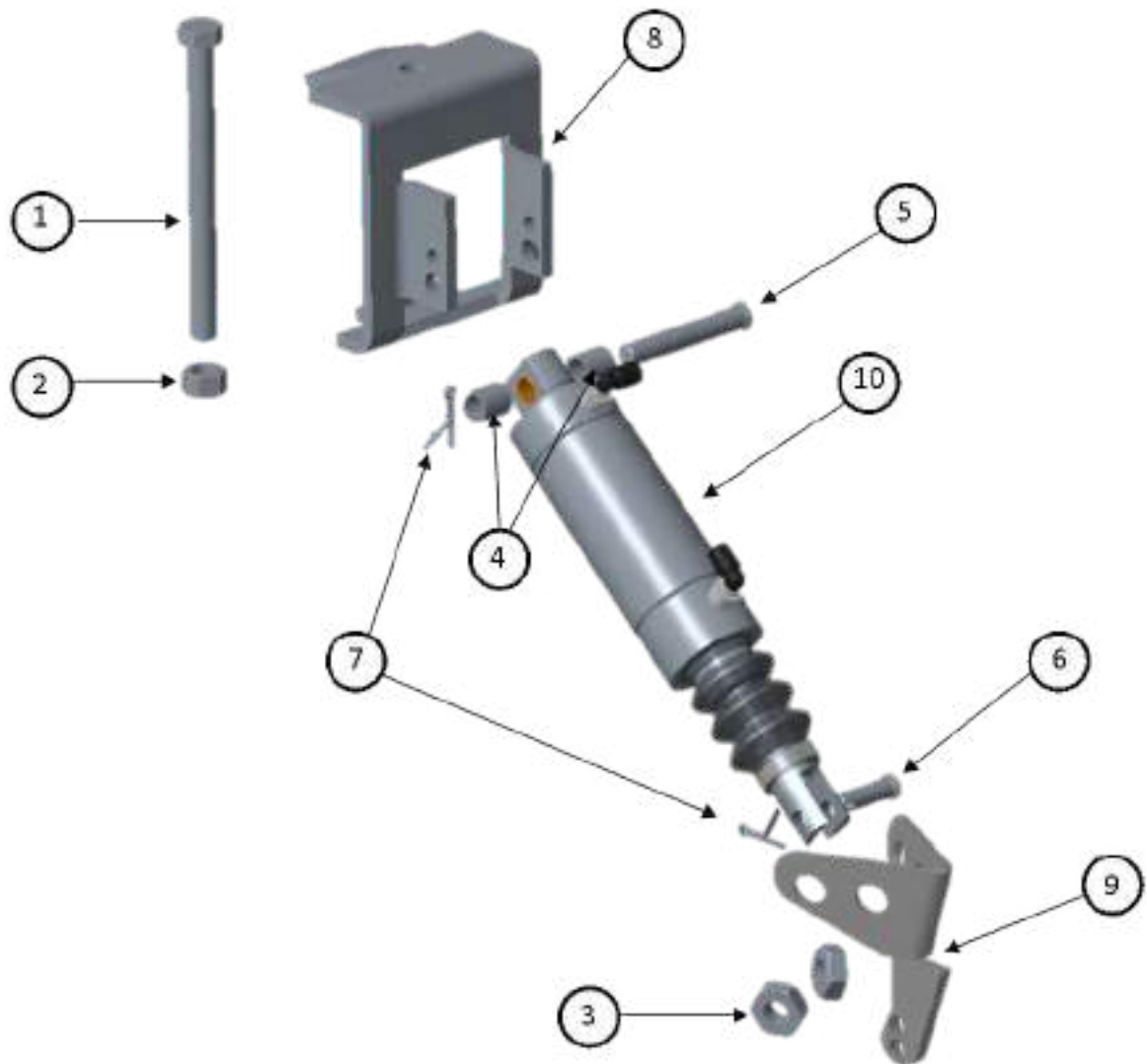

Installation

Step 1:

First, install the cylinder onto the base bracket using the cylinder base pivot pin (755018) and cotter pin.

Use the two spacer bushings (755017) to secure and align the cylinder in the base mount bracket. The cylinder will be installed in the **BOTTOM HOLE**. Do not use the top hole in this kit

Secure the base brackets to the face plate with the 1/2" x 6" bolt and the 1/2" hex nut.



Tighten to 75 lb-ft of torque.

Step 2:

Install the Cylinder Rod Mounting Bracket to the row cleaner frame using the two - 5/8" GRD A ZN Top Lock Jam Nuts. This install will require the removal of the nut and washer present on the D-Bolt (serving as the axle) of the row cleaner. Re-install using the supplied 5/8" Nut and using the Mounting Bracket in place of the washer. Ensure proper alignment of all components, and that the hub is secured and returned to manufacturer's recommendations.

When installing the Cylinder Rod Mount Bracket, be sure it is properly aligned in the clevis yoke of the Rod and firmly seated in the curve of the row cleaner. This may require the exact angle of the bracket to be tweaked or modified in order to more perfectly match the individual row unit.

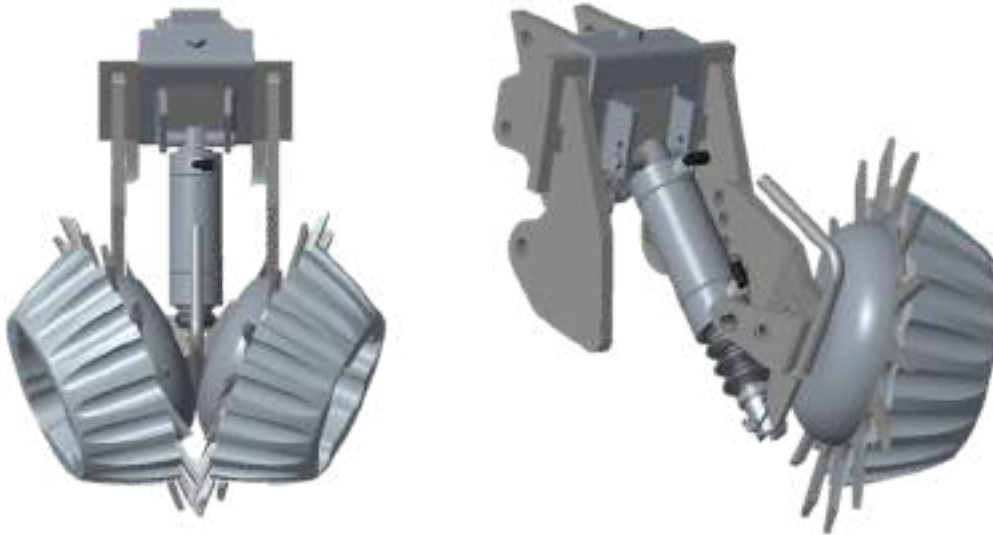

Secure the Rod Mounting Bracket to the clevis yoke on the cylinder using the supplied cylinder rod pivot pin (755019) and cotter pin.

The default Pivot Hole for the Cylinder Rod in this conversion kit is the **TOP HOLE**. Refer to the Mounting Hole Selection guide at the end of this section for more information on which mounting holes to use with this bracket.

When installing the Cylinder Rod Mount Bracket, the first priority is to ensure proper alignment in the clevis yoke of the Rod. There may be considerable slop or play between the clevis yoke and the rod mounting bracket. This is OK and will not negatively affect the performance of the system. This is intended to ease basic installation, especially on mildly deformed row cleaners. Pay close attention to the mounting location of this bracket. Consistent placement from row to row will provide consistent force from row to row and will prevent premature wear on the cylinder.

Verify the freedom of motion and clearance of components. Ensure that the Row Cleaner does not 'hang' on the cylinder when extended. This may require extending the row cleaner until this situation is achieved, then selecting the pin location or stop bolt depth just above this depth.

Completed Cylinder Kit Installation

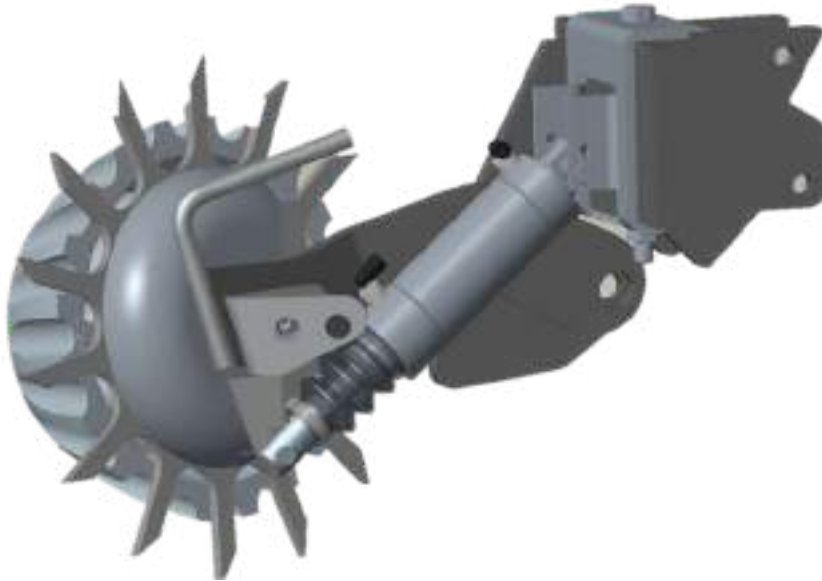

Maintenance Recommendations

If the bellows on the rubber boot become inverted or collapsed, locate the dimple on the rubber boot (near the Cylinder). Pinch the dimple open while articulating the Rod into and out of the Cylinder. This should allow the boot to re-seat properly.

Lubrication: Cylinders are manufactured with a non-migratory grease and should not require additional lubrication under normal operating conditions.

For all Case IH installations, route airlines as shown in Picture 1



Mounting Hole Selection

Use this page to select the mounting location when using the Mounting Bracket — 755157

Note: The default mounting location for the Base bracket is the BOTTOM HOLE. The default mounting location for the Rod bracket is the TOP HOLE.

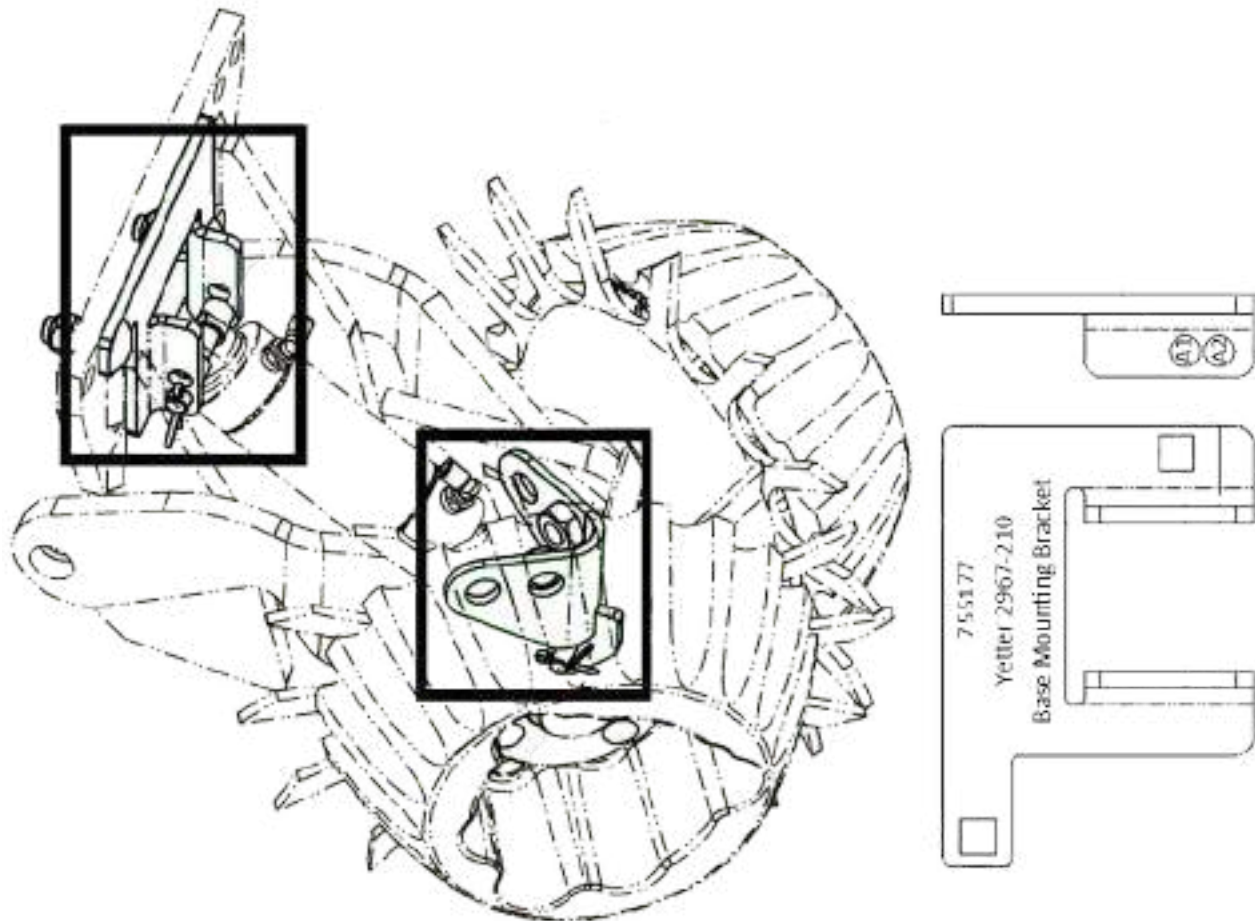

Hole A1 (Top Hole):

- Installing the cylinder in the top holes will INCREASE the magnitude of the force applies to the row cleaner. Therefore;
 - To be used if MORE down force is desired when the system will generally be used in the down direction.
 - To be used if LESS down force is desired when the system will generally be used in the lift direction.

Hole A2 (Bottom Hole):

- Installing the cylinder in the bottom holes will DECREASE the magnitude of the force applied to the row cleaner. Therefore;
 - To be used if LESS down force is desired when the system will generally be used in the down direction.
 - To be used in MORE down force is desired when the system will generally be used in the Lift direction.

Note: In general, all rows will be set to the same hole. However, some rows may require unique settings. A typical example would be a row unit directly behind a tractor tire. In this example, this row unit should be set to exert more force on the row cleaner than the surrounding rows. If the system is normally operated in LIFT mode, install this row unit in the bottom hole. If the system is normally operated in the DOWN mode, install this row unit in the top hole.



Caution: Risk of hyper-extending the row cleaner/cylinder kit beneath the row unit. DO NOT run the stop bolt too deep. The row cleaner should not be allowed to fall below 38 degrees below horizontal; this usually equates to NO LESS than 3/4" of thread showing on the stop bolt below the stop bolt bracket

755255 — Yetter Titan 2967-013A/14A/029A/097A



Kit Components

ITEM	QTY	PART NUMBER	PART NAME	DESCRIPTION
1	1	726107	Fitting	1/4" NPT x 1/4" PTC
2	1	755019	Pin	Cylinder Rod Pivot
3	2	755028	Cotter Pin	1/8" x 1"
4	1	755214	Pin	Cylinder Base Pivot
5	1	755023	Air Cylinder	Complete Cylinder Assembly (Sold Sep.)

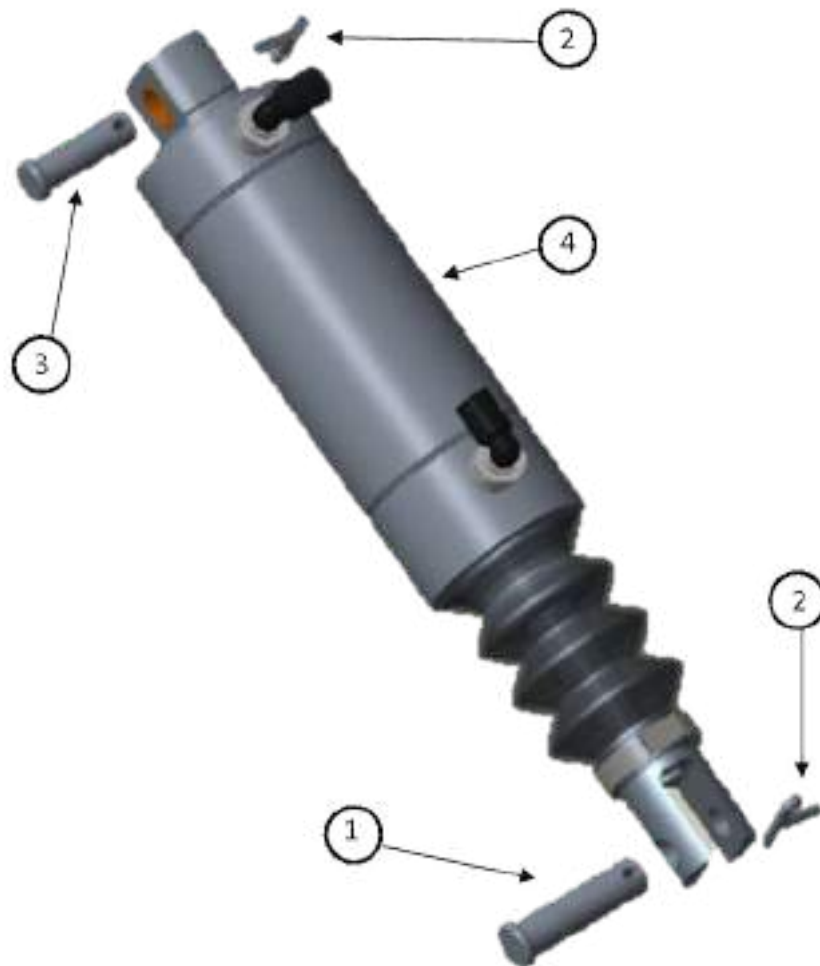

Installation

Step 1:

For better clearance, remove the 1/2" NPT x 1/4" PTC 90 degree elbow from the top of the Air Cylinder. Replace this fitting with the supplied 1/4" NPT 1/4" PTC straight fitting from the hardware kit. This will assist in safe airline routing.

Step 2:

Secure the base of the cylinder to the face plate mount with the base pivot pin (longer pin) and the cotter pin.

Step 3:

Secure the rod of the cylinder to the row cleaner with the rod pivot pin (shorter pin) and cotter pin.

Verify the freedom of motion and clearance of components. Ensure that the Row Cleaner does not 'hang' on the cylinder when extended. This may require extending the row cleaner until this situation is achieved, then selecting the pin location or stop bolt depth just above this depth.

Maintenance Recommendations

If the bellows on the rubber boot become inverted or collapsed, locate the dimple on the rubber boot (near the Cylinder). Pinch the dimple open while articulating the Rod into and out of the Cylinder. This should allow the boot to re-seat properly.

Lubrication: Cylinders are manufactured with a non-migratory grease and should not require additional lubrication under normal operating conditions.

755265 — Yetter Titan 2967-029/097

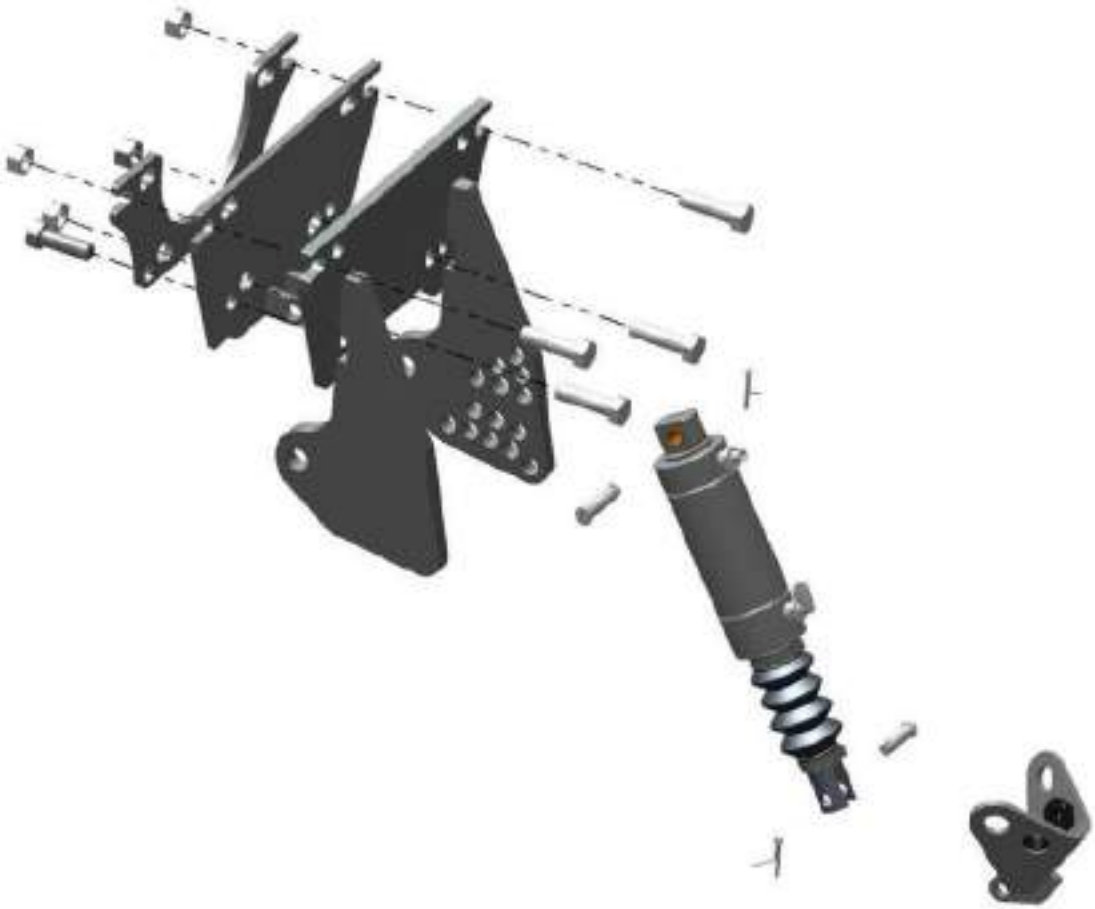

Kit Components

ITEM	QTY	PART NUMBER	PART NAME	DESCRIPTION
1	1	13209	Bolt	1/2"- 13 x 1.5" GRD 5 Carriage
2	4	113210	Hex Nut	1/2"- 13 x 1.75 GRD 5 Bolt
3	4	37268	Jam Nut	1/2"-13 GRD C Toplock Nut
4	2	37273	Jam Top Lock Nut	5/8"-11 GRD A ZN
5	1	726107	Fitting	1/4" NPT x 1/4" PTC
6	1	755019	Pin	Cylinder Rod Pivot
7	1	755023	Air Cylinder	Complete Assembly (Sold Sep.)
8	2	755028	Cotter Pin	1/8" X 1"
9	1	755177	Bracket	2967-029 Rod Mount
10	1	755212	Bracket	2967-007 Rod Mount
11	1	755214	Pin	Cylinder Base Pivot

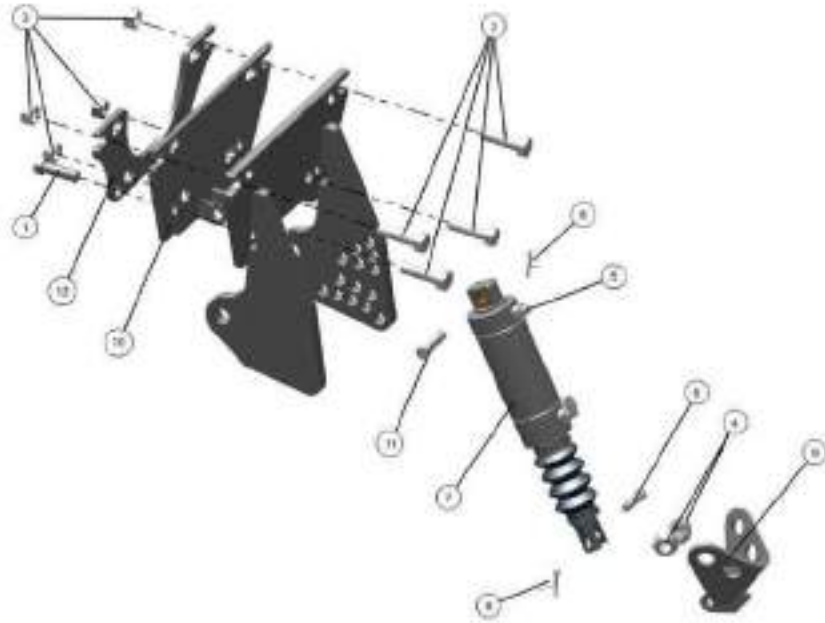

Installation

Step 1:

Secure the Cylinder Base Mounting Bracket to the face plate bracket using the included shim and hardware. The shim will be placed directly on the row unit, followed by the Base Mount (755212), then the row cleaner.

Note: The included shim is directional. If the holes do not line up with the Base Bracket, flip the shim over.

Tighten to 75 lb-ft of torque.

Install the base of the Cylinder to this bracket using the Cylinder Base Pivot Pin (755214).

Step 2:

Install the Cylinder Rod Mounting Bracket to the row cleaner frame using the two - 5/8" GRD A ZN Top Lock Jam Nuts. This install will require the removal of the nut and washer present on the D-Bolt (serving as the axle) of the row cleaner. Re-install using the supplied 5/8" Nut and using the Mounting Bracket in place of the washer. Ensure proper alignment of all components, and that the hub is secured and returned to manufacturer's recommendations



When installing the Cylinder Rod Mount Bracket, be sure it is properly aligned in the clevis yoke of the Rod. This may require the exact angle of the bracket to be tweaked or modified in order to more perfectly match the individual row unit.

Secure the Rod Mounting Bracket to the clevis yoke on the cylinder using the supplied cylinder rod pivot pin (755019) and cotter pin. Refer to the Mounting Hole Selection guide at the end of this section for more information on which mounting holes to use with this bracket.

When installing the Cylinder Rod Mount Bracket, the first priority is to ensure proper alignment in the clevis yoke of the Rod. There may be considerable slop or play between the clevis yoke and the rod mounting bracket. This is OK and will not negatively affect the performance of the system. This is intended to ease basic installation, especially on mildly deformed row cleaners. Pay close attention to the mounting location of this bracket. Consistent placement from row to row will provide consistent force from row to row and will prevent premature wear on the cylinder. The default pivot hole for the cylinder rod is the TOP HOLE of the bracket.

Note: The default pivot hole for the cylinder rod is the TOP HOLE in the bracket.

Verify the freedom of motion and clearance of components.

Ensure that the Row Cleaner does not ‘hang’ on the cylinder when extended. This may require extending the row cleaner until this situation is achieved, then selecting the pin location or stop bolt depth just above this depth.

Completed Cylinder Kit Installation



Maintenance Recommendations

If the bellows on the rubber boot become inverted or collapsed, locate the dimple on the rubber boot (near the Cylinder). Pinch the dimple open while articulating the Rod into and out of the Cylinder. This should allow the boot to re-seat properly.

Lubrication: Cylinders are manufactured with a non-migratory grease and should not require additional lubrication under normal operating conditions.

Mounting Hole Selection: 2967–029/097

For this conversion kit, the default Rod Mounting location is the TOP HOLE.

Top Hole:

- Installing the cylinder in the top holes will INCREASE the magnitude of the force applied to the row cleaner.



Bottom Hole:

- Installing the cylinder in the bottom holes with DECREASE the magnitude of the force applied to the row cleaner.

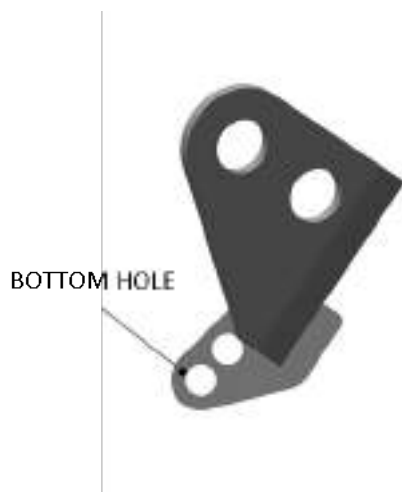

Note: In general, all rows will be set to the same hole. However, some rows may require unique settings. A typical example would be a row unit directly behind a tractor tire. In this example, this row unit should be set to exert more force on the row cleaner than the surrounding rows. If the system is normally operated in LIFT mode, install this row unit in the bottom hole. If the system is normally operated in the DOWN mode, install this row unit in the top hole.



Caution: Risk of hyper-extending the row cleaner/cylinder kit beneath the row unit. DO NOT run the stop bolt too deep. The row cleaner should not be allowed to fall below 38 degrees below horizontal; this usually equates to NO LESS than 3/4" of thread showing on the stop bolt below the stop bolt bracket

Kit Components

ITEM	QTY	PART NUMBER	PART NAME	DESCRIPTION
1	1	13209	Bolt	1/2"- 13 x 1.5" GRD 5 Carriage
2	4	13210	Hex Nut	1/2"- 13 x 1.75 GRD 5 Bolt
3	4	37268	Jam Nut	1/2"-13 GRD C Toplock Nut
4	2	37273	Jam Top Lock Nut	5/8"-11 GRD A ZN
5	1	726107	Fitting	1/4" NPT x 1/4" PTC
6	1	755019	Pin	Cylinder Rod Pivot
7	1	755023	Air Cylinder	Complete Assembly (Sold Sep.)
8	2	755028	Cotter Pin	1/8" X 1"
9	1	755177	Bracket	2967-029 Rod Mount
10	1	755212	Bracket	2967-007 Rod Mount
11	1	755214	Pin	Cylinder Base Pivot

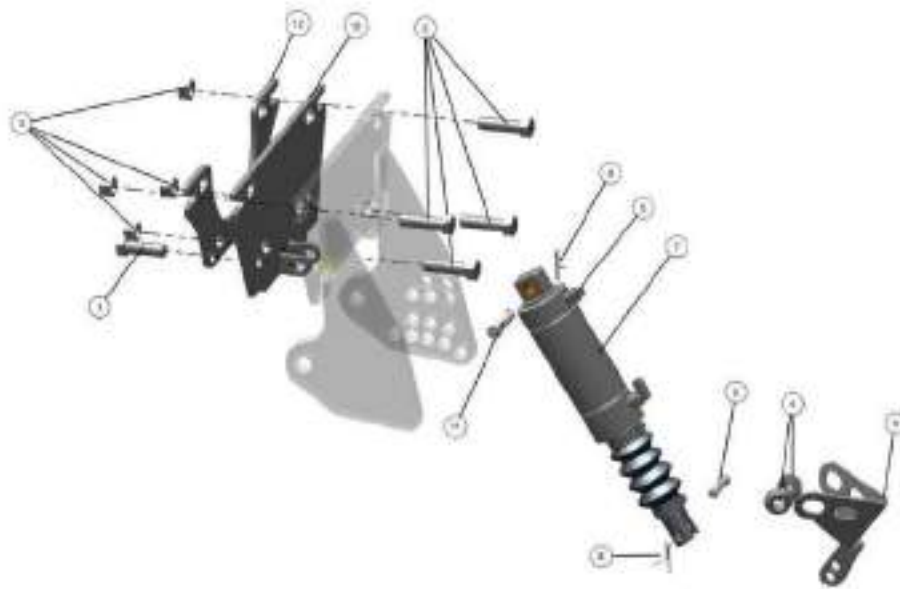

Installation

Step 1:

Secure the Cylinder Base Mounting Bracket to the face plate bracket using the included shim and hardware. The shim will be placed directly on the row unit, followed by the Base Mount (755212), then the row cleaner.

Note: The included shim is directional. If the holes do not line up with the Base Bracket, flip the shim over.

Tighten to 75 lb-ft of torque.

Install the base of the Cylinder to this bracket using the Cylinder Base Pivot Pin (755214).

Step 2:

Install the Cylinder Rod Mounting Bracket to the row cleaner frame using the two - 5/8" GRD A ZN Top Lock Jam Nuts. This install will require the removal of the nut and washer present on the D-Bolt (serving as the axle) of the row cleaner. Re-install using the supplied 5/8" Nut and using the Mounting Bracket in place of the washer. Ensure proper alignment of all components, and that the hub is secured and returned to manufacturer's recommendations. This install will require the removal of the nut and washer present on the D-Bolt (serving as the axle) of the row cleaner. Re-install using the supplied 5/8" Nut and using the Mounting Bracket in place of the washer. Ensure proper alignment of all components, and that the hub is secured and returned to manufacturer's recommendations.



When installing the Cylinder Rod Mount Bracket, be sure it is properly aligned in the clevis yoke of the Rod. This may require the exact angle of the bracket to be tweaked or modified in order to more perfectly match the individual row unit.

Secure the Rod Mounting Bracket to the clevis yoke on the cylinder using the supplied cylinder rod pivot pin (755019) and cotter pin. Refer to the Mounting Hole Selection guide at the end of this section for more information on which mounting holes to use with this bracket.

When installing the Cylinder Rod Mount Bracket, the first priority is to ensure proper alignment in the clevis yoke of the Rod. There may be considerable slop or play between the clevis yoke and the rod mounting bracket. This is OK and will not negatively affect the performance of the system. This is intended to ease basic installation, especially on mildly deformed row cleaners. Pay close attention to the mounting location of this bracket. Consistent placement from row to row will provide consistent force from row to row and will prevent premature wear on the cylinder. The default pivot hole for the cylinder rod is the TOP HOLE of the bracket.

Note: The default pivot hole for the cylinder rod is the TOP HOLE in the bracket.

Verify the freedom of motion and clearance of components.

Ensure that the Row Cleaner does not ‘hang’ on the cylinder when extended. This may require extending the row cleaner until this situation is achieved, then selecting the pin location or stop bolt depth just above this depth.

Completed Cylinder Kit Installation



Maintenance Recommendations

If the bellows on the rubber boot become inverted or collapsed, locate the dimple on the rubber boot (near the Cylinder). Pinch the dimple open while articulating the Rod into and out of the Cylinder. This should allow the boot to re-seat properly.

Lubrication: Cylinders are manufactured with a non-migratory grease and should not require additional lubrication under normal operating conditions.

Mounting Hole Selection: 2967–029/097

For this conversion kit, the default Rod Mounting location is the TOP HOLE.

Top Hole:

- Installing the cylinder in the top holes will INCREASE the magnitude of the force applied to the row cleaner.



Bottom Hole:

- Installing the cylinder in the bottom holes with DECREASE the magnitude of the force applied to the row cleaner.



Note: In general, all rows will be set to the same hole. However, some rows may require unique settings. A typical example would be a row unit directly behind a tractor tire. In this example, this row unit should be set to exert more force on the row cleaner than the surrounding rows. If the system is normally operated in LIFT mode, install this row unit in the bottom hole. If the system is normally operated in the DOWN mode, install this row unit in the top hole.



Caution: Risk of hyper-extending the row cleaner/cylinder kit beneath the row unit. DO NOT run the stop bolt too deep. The row cleaner should not be allowed to fall below 38 degrees below horizontal; this usually equates to NO LESS than 3/4" of thread showing on the stop bolt below the stop bolt bracket

Connecting/Routing the Air Lines

Note: This process should be done with the planter raised, half folded for transport, and the row units and row cleaners fully extended down. The Planter should be cleaned prior to routing the airlines. Dust or dirt introduced into the system during installation will cause premature wear and failure of the cylinders.

The lines and fittings kit supplied is designed to enable the connection from the air supply-source to the controller and both circuits (Down and Lift) from the controller to the cylinders.

Due to the wide variety of planter/row unit configurations, you should adapt the installation as necessary for your planter. Every planter will contain its own unique situations in regard to routing the lines. **You should exercise your own best judgment to fit your situation.**

The primary concern is the security of the lines themselves. The lines should be fastened to the planter in a manner that allows full range of motion/clearance of the row unit. Special caution should be taken around rows at break or fold points of the planter as it folds to and unfolds from transport mode. Extra lengths of slack or alternative routing may be necessary.

- ALL lines will be 1/4" tubing
- Use Brown Tubing as supply air from the compressor
- Black tubing — used for routing to DOWN pressure •
Silver tubing — used for routing to LIFT pressure
- Temperature and pressure specifications are the same for both colors of tubing
- Flow is of little importance — lines should be placed as efficiently and conveniently as possible
- Secure the Air Lines using the supplies zip tie straps — do not pinch the line closed when cinching tight
- The 1/4" lines should be secured and routed back to the main bar to be Tee'd into the circuit. This will effectively create a 'Main' or 'Trunk' line that can be safely secured on the planter frame.
- DO NOT pre-cut the line, measure and layout each length individually.

After completion of the **FIRST** row and **PRIOR** to continuing to other rows, check for clearance of, and lack of pinch points on all lines and fittings. This should be done by completely raising and lowering both the row unit and row cleaner to their extremes, making sure the tubes are not pinched or exposed to wear points throughout the movement of the row unit. (see row unit line routing image on following pages).

Note: All AirForce and CleanSweep compressors include a tubing cutter within the service kit. This cutter should be used for every cut, to ensure a clean, square cut.



Air Lines Routing — Overview

Note: For conversion kits: 755160,755175, 755180, 755180, 755190, 755195, 755200, 755205, 755215, 755235, 755240, 755245, 755250, and 755255

The lines and fittings kit supplied is designed to enable the connection from the air supply-source to the controller and both circuits (Down and Lift) from the controller to the cylinders.

Direction of flow is from **Supply Tank** to **Controller** to **Lift and Down lines** out to **Cylinders**. All lines will be 1/4" because flow is of little importance. Increasing the lines size to 3/8" will not increase reactivity or increase performance. The flow restriction of the 1/4" tubing is negligible compared to the restriction at the regulator. Route the lines as efficiently and conveniently as possible. Use the colors to differentiate the lines on the planter frame. This will facilitate maintenance, trouble-shooting, and leak detection

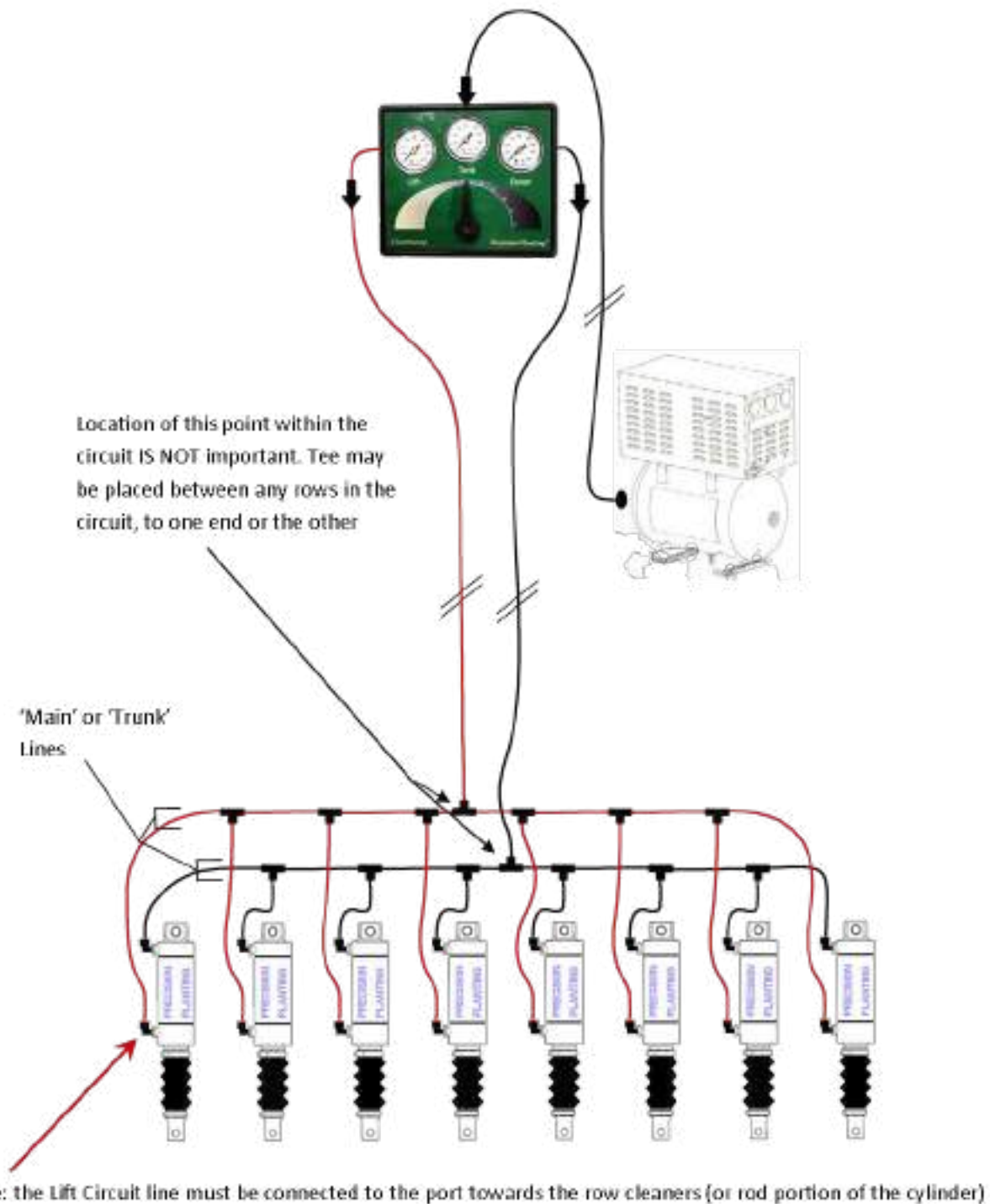

Note: For conversion kits: 755170, 755225, 755230

The lines and fittings kit supplied is designed to enable the connection from the air supply-source to the controller and both circuits (Down and Lift) from the controller to the cylinders.

Direction of flow is from **Supply Tank** to **Controller** to **Lift and Down lines** out to **Cylinders**. All lines will be 1/4" because flow is of little importance. Increasing the lines size to 3/8" will not increase reactivity or increase performance. The flow restriction of the 1/4" tubing is negligible compared to the restriction at the regulator. Route the lines as efficiently and conveniently as

possible. Use the colors to differentiate the lines on the planter frame. This will facilitate maintenance, trouble-shooting, and leak detection

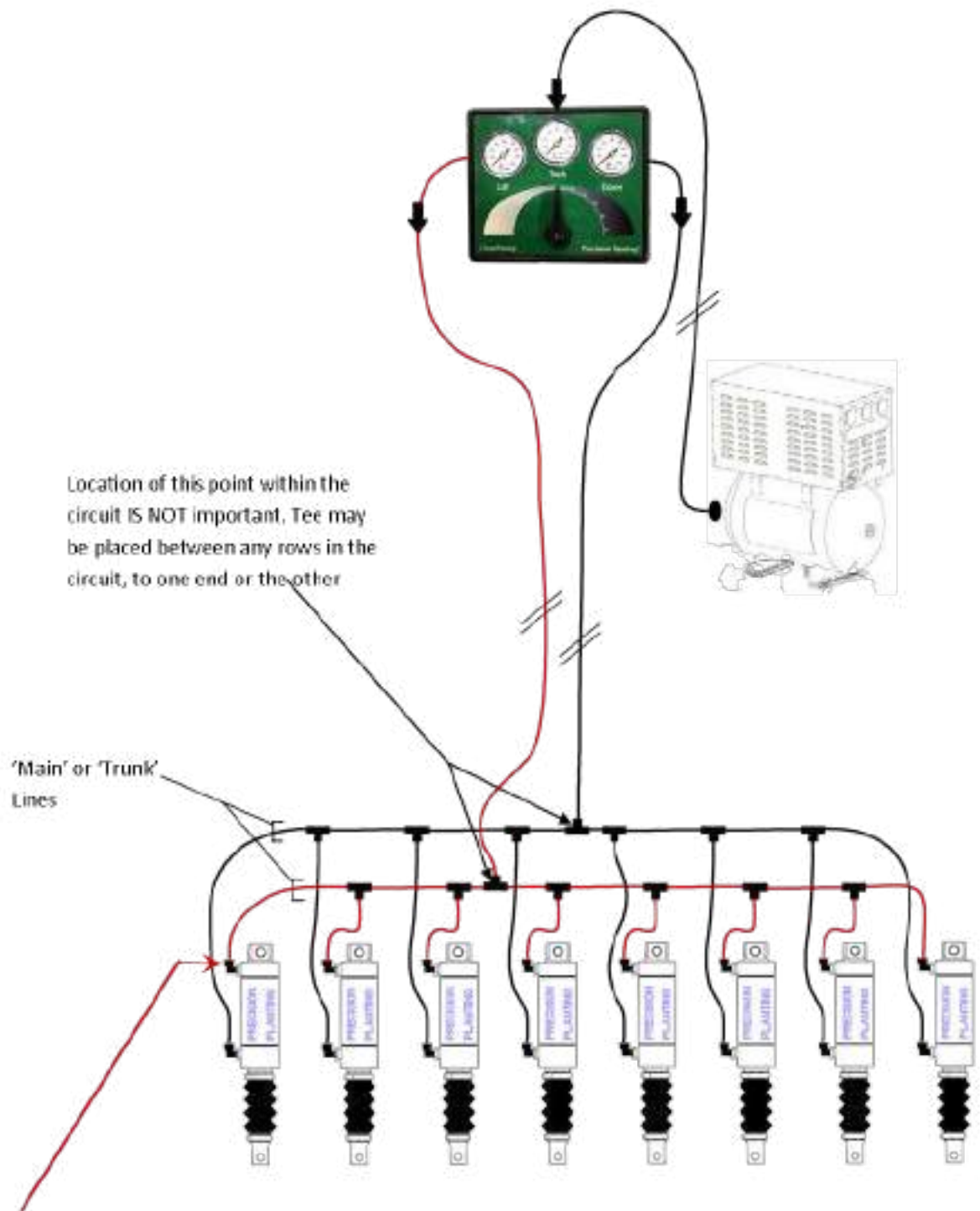

Air Lines Routing — Row Unit

Below is a suggested method for safely and securely routing the air lines from the cylinder to planter frame. These are generalizations, and **YOU SHOULD USE YOUR OWN BEST JUDGEMENT** in routing air lines

Specific airline routing will be dependent on: Row unit make (JD, Kinze, etc...), parallel arm length, cylinder fittings orientation, coulter, row cleaner make, row cleaner model, and planter specific instances.

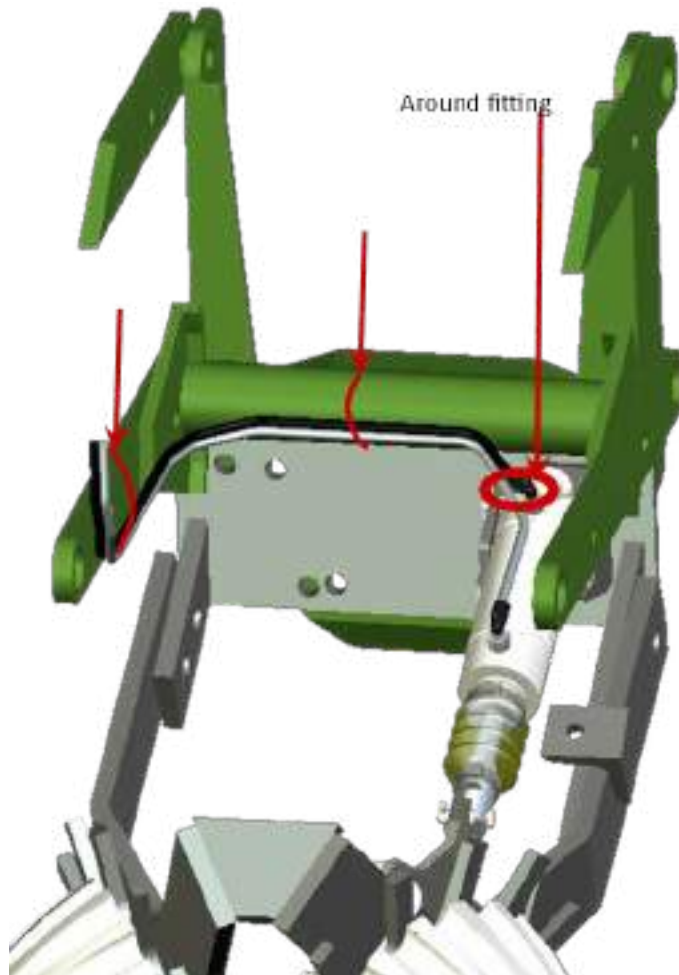

DO NOT pass the lines between the rear cylinder of the parallel arms and the row unit. This can act as both a pinch point and wear point.

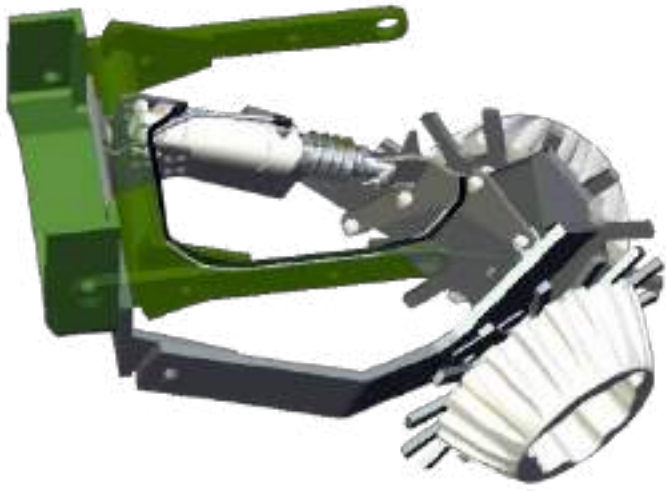

Air Lines Fittings Kits

8 Row Air Lines and Fittings Kit — 755035

QTY	PART NUMBER	NOTE	PART NAME	DESCRIPTION
36	63128	C	Tie Strap	12" UV Black
4	726103	B	PTC Plug	1/4" Plug
16	726115	D	Tee	1/4" X 1/4" X 1/4" PTC Tee
2	726171	B	PTC Union	1/4" X 1/4" PTC
1	755052	A	Tubing	1/4" OD 100' Black
1	755053	A	Tubing	1/4" OD 100' Silver

NOTES	
A	Use for plumbing between controller, main trunk line, and rows. Cut to length.
B	Use for repairs as necessary
C	Use as required to secure tubing
D	Use to connect row unit tubing to main trunk line

QTY	PART NUMBER	NOTE	PART NAME	DESCRIPTION
48	63128	C	Tie Strap	12" UV Black
4	726103	B	PTC Plug	1/4" Plug
24	726115	D	Tee	1/4" X 1/4" X 1/4" PTC Tee
2	726171	B	PTC Union	1/4" X 1/4" PTC
1	755056	A	Tubing	1/4" OD 150' Black
1	755057	A	Tubing	1/4" OD 150' Silver

NOTES	
A	Use for plumbing between controller, main trunk line, and rows. Cut to length.
B	Use for repairs as necessary
C	Use as required to secure tubing
D	Use to connect row unit tubing to main trunk line

16 Row Air Lines and Fittings Kit — 755085

QTY	PART NUMBER	NOTE	PART NAME	DESCRIPTION
72	63128	C	Tie Strap	12" UV Black
4	726103	B	PTC Plug	1/4" Plug
32	726115	D	Tee	1/4" X 1/4" X 1/4" PTC Tee
2	726171	B	PTC Union	1/4" X 1/4" PTC

1	755058	A	Tubing	1/4" OD 200' Black
1	755059	A	Tubing	1/4" OD 200' Silver

NOTES	
A	Use for plumbing between controller, main trunk line, and rows. Cut to length.
B	Use for repairs as necessary
C	Use as required to secure tubing
D	Use to connect row unit tubing to main trunk line

24 Row Air Lines and Fittings Kit — 755045

QTY	PART NUMBER	NOTE	PART NAME	DESCRIPTION
96	63128	C	Tie Strap	12" UV Black
4	726103	B	PTC Plug	1/4" Plug
48	726115	D	Tee	1/4" X 1/4" X 1/4" PTC Tee
2	726171	B	PTC Union	1/4" X 1/4" PTC
1	755052	A	Tubing	1/4" OD 100' Black
1	755053	A	Tubing	1/4" OD 100' Silver
1	755056	A	Tubing	1/4" OD 150' Black
1	755057	A	Tubing	1/4" OD 150' Silver

NOTES	
A	Use for plumbing between controller, main trunk line, and rows. Cut to length.
B	Use for repairs as necessary
C	Use as required to secure tubing
D	Use to connect row unit tubing to main trunk line

36 Row Air Lines and Fittings Kit — 755050

QTY	PART NUMBER	NOTE	PART NAME	DESCRIPTION
144	63128	C	Tie Strap	12" UV Black
4	726103	B	PTC Plug	1/4" Plug
72	726115	D	Tee	1/4" X 1/4" X 1/4" PTC Tee
2	726171	B	PTC Union	1/4" X 1/4" PTC
1	755056	A	Tubing	1/4" OD 150' Black
1	755057	A	Tubing	1/4" OD 150' Silver
1	755058	A	Tubing	1/4" OD 200' Black
1	755059	A	Tubing	1/4" OD 200' Silver

NOTES	
A	Use for plumbing between controller, main trunk line, and rows. Cut to length.
B	Use for repairs as necessary
C	Use as required to secure tubing
D	Use to connect row unit tubing to main trunk line

48 Row Air Lines and Fittings Kit — 755065

QTY	PART NUMBER	NOTE	PART NAME	DESCRIPTION
192	63128	C	Tie Strap	12" UV Black
4	726103	B	PTC Plug	1/4" Plug
96	726115	D	Tee	1/4" X 1/4" X 1/4" PTC Tee
2	726171	B	PTC Union	1/4" X 1/4" PTC
2	755058	A	Tubing	1/4" OD 200' Black
2	755059	A	Tubing	1/4" OD 200' Silver

NOTES	
A	Use for plumbing between controller, main trunk line, and rows. Cut to length.
B	Use for repairs as necessary
C	Use as required to secure tubing
D	Use to connect row unit tubing to main trunk line

54 Row Air Lines and Fittings Kit — 755070

QTY	PART NUMBER	NOTE	PART NAME	DESCRIPTION
204	63128	C	Tie Strap	12" UV Black
4	726103	B	PTC Plug	1/4" Plug
104	726115	D	Tee	1/4" X 1/4" X 1/4" PTC Tee
2	726171	B	PTC Union	1/4" X 1/4" PTC
3	755056	A	Tubing	1/4" OD 150' Black
3	755057	A	Tubing	1/4" OD 150' Silver

NOTES	
A	Use for plumbing between controller, main trunk line, and rows. Cut to length.
B	Use for repairs as necessary
C	Use as required to secure tubing
D	Use to connect row unit tubing to main trunk line